

RESTRICTED

The information given in this document  
is not to be communicated, either  
directly or indirectly, to the Press or to  
any person not authorized to receive it.

W.O.  
CODE NO.  
10229/1

USER HANDBOOK  
(PROVISIONAL)

FOR THE  
LAUNCHER, ROCKET, 3.5 INCH U.K. M.20, MK.2  
1952  
AMENDMENTS (NO.1)

1. Page 2 para. 2.0 line 6 Add -

Barrels are not perfectly interchangeable, and, in accordance with E.M.E.R. Armt. T307, Mod. Inst. No.4, the registered number of the equipment is stamped near the rear end of the front barrel. Moreover, the word TOP is painted in white just forward of this number, to give the User a quick indication of the best of three possible assembly positions.

2. Page 10 para. 14.0 line 3 After "secured" insert ", the word TOP should be uppermost"
3. Page 21 para. 31.0 line 5 After "barrel" insert "so that on completion the word TOP is uppermost".
4. Page 34 para. 47.0 -  
Delete lines 1 and 2  
Line 3 Delete commas after "line" and "graticule" and insert comma after "board"  
Delete from "when" in line 4 to "positions" in line 5.
5. Page 36 para. 47.0 -  
Line 2 Delete "when the barrel is in each of the three locked positions"  
Delete lines 3 and 4

October, 1955.  
IA/MP 60/1

DIRECTOR OF INFANTRY  
WAR OFFICE

**RESTRICTED**

The information given in this document is not to be communicated, either directly or indirectly, to the Press or to any person not authorized to receive it.

W.O. CODE  
NO. 10229

USER HANDBOOK  
(PROVISIONAL)

for the

LAUNCHER, ROCKET, 3.5 INCH U.K. M20, MK. 2

1952

AMENDMENTS (NO. 2)

MANUSCRIPT AMENDMENTS

PAGE 9

Para. 11.0 Line 6 - Delete "soft iron" and substitute "steel".

PAGE 14

Fig. 14 at end of title insert "(Typical)".

PAGE 15

Fig. 15

At end of title insert "(Typical)"

Under "HE FILLING" on illustration - Delete "(RDX/TNT/50/50)"

PAGE 16

Fig. 16 - after "FUZE", in title insert "PERCUSSION"

PAGE 17

Para. 23.0 - Delete "The fuze (Fig. 16) in line 1 and substitute "The L5 fuze (Fig. 16) is fitted to Mark 1, 1/1 and 1/2 rockets and"

IA/MP/60/2



PAGE 17

Para. 23.0 - Delete "The fuze (Fig. 16) in line 1 and substitute "The L5 fuze (Fig.16) is fitted to Mark 1, 1/1 and 1/2 rockets and"

Para.27.0 - line 2 - Delete "wire bridge" and substitute "Fuze, electric, 15-in, No. F.53 Mk. 1/1"

PAGE 20

Para. 30.0 - Delete "Fuzes Practice" and substitute "Fuze, Practice, L5, Mark 2"

PAGE 29

Para. 38.0 - Between "Action" and "on" in heading insert "of the L5 fuze"

PAGE 30

Fig. 27 - Delete "(R.D.X./TNT/50/50)"  
Insert new Figs. 27a and 27b attached.

PAGE 32

Para. 43.1 - Delete from second "firing" in line 1 to "tester" in line 2 and substitute "Tester", electrical output generator, Mk. 1"

PAGE 33

Fig. 29

Delete "FRONT PLUG" and all detail

After Fig. 29 - Delete "Bore Plugs" and substitute "Rear Plug".

PAGE 34

Para. 46.0 - Line 1 - Delete "an adjustable wrench" and substitute "a 5/16 inch SAE spanner."

PAGE 39

Delete existing page 39 and substitute new page 39, 39a, and 39b attached.

CUT-OUT AMENDMENTS

PAGE 10

Delete existing para. 16.0 and substitute new para. 16.0  
Amdt. 2/Aug./1960.

16.0 The muzzle flash deflector (Fig. 10) which is formed at the front of the barrel, diverts blast and particles of unburned powder which might otherwise strike the user. On the front rim of the deflector four notches facilitate the attachment of muzzle cross wires when testing the alignment of the sight.

PAGE 15

Delete existing para. 21.0 and substitute new para.  
Amdt. 2/Aug./1960.

21.0. Introduction

The various types of rocket are:-

Rocket, 3.5in. HE ATK UK M28, Marks 1, 1/1, 1/2 and 2.

Rocket, 3.5 in. Practice UK M29, Mark 2

Rocket, 3.5 in. Drill, L1A1

For the characteristic differences between the various natures and Marks see para. 50.  
The rocket is issued assembled and is loaded into the launcher as a unit. It consists of a rocket head, a fuze and a motor, to the rear of which the tail assembly is attached.  
The complete rocket is shown at Figs 14 and 15.

PAGE 17

After para. 23.0 insert new para. 23A and new fig 16A attached.  
Amdt. 2/Aug./1960.

23A. The L16A1 fuze (Fig 16A) is fitted to Mark 2 rockets. It differs principally from the L5 fuze in being fitted with a safety shutter.

The shutter is fitted with two pins which bear against the scale of the ejection pin to lock the shutter in the unarmed position.

PAGE 20

Delete existing para. 29.0 and substitute  
Amdt. 2/Aug./1960.

29.0 Rocket, 3.5 inch, Practice, UK M29, Mk. 2

This rocket is the same size and weight, and has the same flight characteristics as the service rocket. The head is of steel and is filled with an inert substance to give the required weight. (Earlier Marks of practice rockets were fitted with heads consisting of cast iron bodies and steel ogives and having no filling).

PAGE 30

After Fig. 27 insert new para. 38A -  
Amdt. 2/Aug./1960.

38A. Action of the L16A2 fuze on firing

The action of this fuze (Figs. 27a to 27c) is generally similar to that of the L5 fuze excepting for the operation of the safety shutter, when the ejection pin is ejected (para. 38.0) the shutter is released and, under the influence of the shutter spring is rotated to the armed position where it is locked by the shutter retaining spring. In this position the detonator is aligned with the striker and stemmed CE Channel.

PAGE 33

Delete existing para. 45.1.1 and substitute new para.  
Amdt. 2/Aug./1960.

45.1.1 Fit crosswires to the muzzle end of the launcher and the rear plug into the rear end.

PAGE 41

Delete existing para. 51.0 and substitute new para. -  
Amdt. 2/Aug./1960.

51.0 Packing

For full current packing details see tables 3 and 4, Pamph. 11 Part 1, R.A.O.S. Vol. 4 - Ammunition (WO Code No. 12354).

IA/MP/60/2

PAGE 43

Para. 52.2 delete - line 3 of page and substitute  
Amdt. 2/Aug/1960.

In order to differentiate between HE and practice rocket motors, which are identical, practice rockets filled after the 23rd April 1954 have a white ring, approximately 1 inch wide, painted immediately below the propellant detail on the rocket motor body and a white ring, approximately 1/2 inch wide, immediately below the contact ring.

Details, with the exception of white rings are shown at Fig. 32.

DIRECTOR OF INFANTRY  
WAR OFFICE

August, 1960.

IA/MP/60/2

PART 3 CARE AND MAINTENANCE

SECTION 2 AMMUNITION

50.0 Table of Ammunition - Characteristics of Marks.

50.1 Rockets 3.5 in., H.E.A. Tk., U.K. M28

| Item | Nomenclature     | Complete round |                      | Rocket head |               |                  |                                 | Rocket motor |  |                            |                 | Fuze                             |                 | Firing temperature limits (°F) | Remarks  |
|------|------------------|----------------|----------------------|-------------|---------------|------------------|---------------------------------|--------------|--|----------------------------|-----------------|----------------------------------|-----------------|--------------------------------|--|
|      |                  | Length (in.)   | Approx. Weight (lb.) | Mark        | Filling       | Explosive        | Weight of bursting charge (lb.) | Mark         | Propellant   | Weight of propellant (oz.) | Mark of Igniter | Nomenclature                     | Type            |                                |  |
| (a)  | (b)              | (c)            | (d)                  | (e)         | (f)           | (g)              | (h)                             | (j)          | (k)  | (l)                        | (m)             | (n)                              | (o)             | (p)                            | (q)  |
| 1    | U.K. M28 Mk.1    | 23.55          | 8.9                  | 1           | RDX/TNT 50/50 | 8-dr C.E. Pellet | 1.82 (approx.)                  | 1            | M7 (British) 375-121 or 375-110 (tubular) 12 sticks each 5 in. long  | 5.63 (approx.)             | 1/1             | Fuze, Perc., L5. U.K. M404, Mk.1 | Perc. non-delay | -20 to 120                     | (i) Obsolescent.   |
| 2    | U.K. M28 Mk. 1/1 | 23.55          | 8.9                  | 1/1         | RDX/TNT 60/40 | None             | 1.82 (approx.)                  | 1            | M7 (British) 375-121 or 375-110 (tubular) 12 sticks each 5 in. long  | 5.64 (approx.)             | 1/1             | Fuze, Perc., L5. U.K. M404, Mk.1 | Perc. non-delay | -20 to 120                     | (i) Differs from Mk.1 in mark of rocket head.<br>(ii) Obsolescent. |
| 3    | U.K. M28 Mk. 1/2 | 23.55          | 8.9                  | 1/1         | RDX/TNT 60/40 | None             | 1.82 (approx.)                  | 1/1          | M7 (British) 375-121 or 375-110 (tubular) 12 sticks each 5 in. long. | 5.63 (approx.)             | 1/2             | Fuze, Perc., L5. U.K. M404, Mk.1 | Perc. non-delay | -20 to 120                     | (i) Differs from Mk.1/1 in mark of igniter used.                   |
| 4    | U.K. M28 Mk. 2   | 23.55          | 8.9                  | 1/1         | RDX/TNT 60/40 | None             | 1.82 (approx.)                  | 1/1          | M7 (British) 375-121 or 375-110 (tubular) 12 sticks each 5 in. long  | 5.64 (approx.)             | 1/2             | Fuze, Perc., L16A1               | Perc. non-delay | -20 to 120                     | (i) Differs from Mk. 1/2 in type of fuze only.                     |

IA/MP/60/2

50.2 Rockets, 3.5 in., PRACTICE, U.K. M29

| Item | Nomenclature      | Complete round |                      | Rocket head |         |                                 | Rocket motor |   |                      |                 | Fuse nomenclature         | Firing temperature limits (°F) | Remarks   |
|------|-------------------|----------------|----------------------|-------------|---------|---------------------------------|--------------|---|----------------------|-----------------|---------------------------|--------------------------------|---|
|      |                   | Length (in)    | Approx. weight (lb.) | Mark        | Filling | Weight of bursting charge (lb.) | Mark         | Propellant  | Weight of Propellant | Mark of Igniter |                           |                                |   |
| (a)  | (b)               | (c)            | (d)                  | (e)         | (f)     | (g)                             | (h)          | (j)   | (k)                  | (l)             | (m)                       | (n)                            | (o)   |
| 1.   | U.K. M.29 Mk.1    | 23.55          | 8.9                  | -           | None    | -                               | 1            | M7 (British) 375-121 or 375-110 (tubular) 12 Sticks each 5 in. long | 5.64                 | 1/1             | Fuze Practice, L5, Mk. 2  | -20 to 120                     | (i) Obsolescent.  |
| 2    | U.K. M.29 Mk. 1/1 | 23.55          | 8.9                  | -           | None    | -                               | 1/1          | M7 (British) 375-121 or 375-110 (tubular) 12 Sticks each 5 in. long | 5.64                 | 1/2             | Fuze, Practice, L5, Mk. 2 | -20 to 120                     | (i) Differs from Mk. 1 in mark of igniter used.   |
| 3    | U.K. M.29 Mk.2    | 23.55          | 8.9                  | 1 (empty)   | H.E.S.  | -                               | 1/1          | M7 (British) 375-121 or 375-110 (tubular) 12 Sticks each 5 in. long | 5.64                 | 1/2             | Fuze, Practice, L5, Mk. 2 | -20 to 120                     | (i) Differs from Mk. 1/1 in that the rocket head used is the empty H.E. head weighted with H.E.S. |

IA/MP/60/2

50.3 Rockets, 3.5 in., DRILL

| Item Model No. |      | Complete round |                      | Rocket head                      | Rocket motor | Fuze                  |
|----------------|------|----------------|----------------------|----------------------------------|--------------|-----------------------|
|                |      | Length (in.)   | Approx. weight (lb.) |                                  |              |                       |
| (a)            | (b)  | (c)            | (d)                  | (e)                              | (f)          | (g)                   |
| 1              | L1A1 | 23.55          | 8.9                  | Service or Practice Filled inert | Inert        | Fuze, Drill, L5 Mk. 1 |

Remarks:-

Head detail, - Head, Practice, 3.5 in. U.K. M29, Rocket, Mk. 1, or Head, 3.5 in., H.E.A.Tk., U.K. M28, Rocket, Empty, Mk. 1, filled with 1.9 lb. of Checkol.

Motor detail, - An inert drill motor made up of empty, new or rejected Service components.

Fuze detail, - Fuze, Drill, L5, Mk. 1. This fuze was introduced in 1950 as Fuze, Practice, L5, Mk. 1, and amended to present nomenclature in April, 1956. The fuze represents the Fuze, Percussion, L16A1 and L5 U.K. M404. It consists of an anodised aluminium alloy body with a steel pin driven in to represent the ejection pin and is fitted with a safety band.

IA/MF/60/2

# FUZE, PERCUSSION, LI6AI. - ACTION

FIG.27A

ON FIRING-  
UNARMED

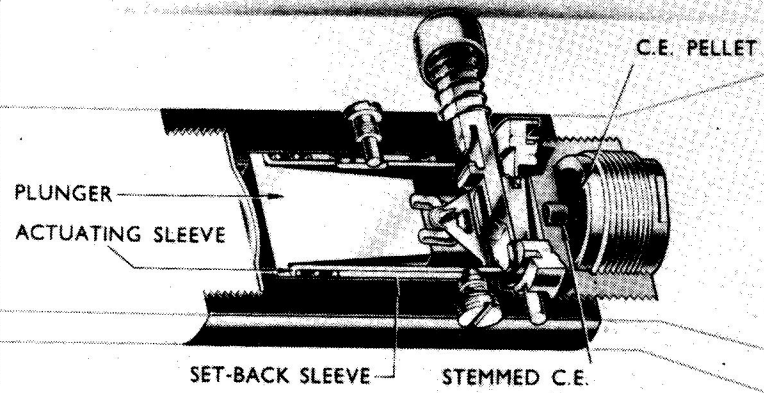
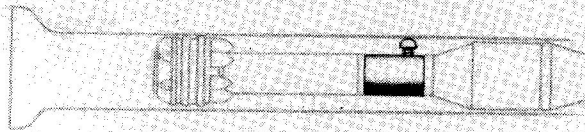

ACTION OF STRIKER

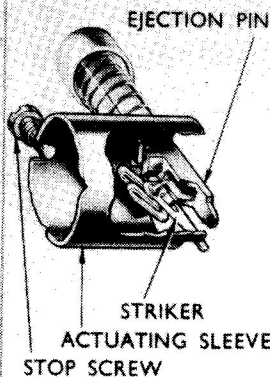

ACTION OF SHUTTER

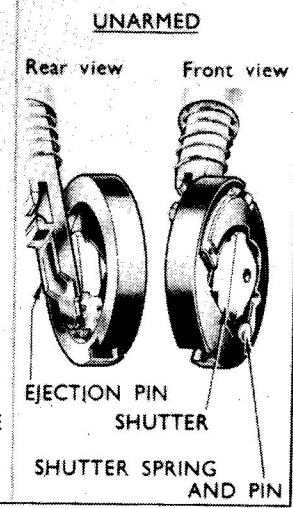



# FUZE, PERCUSSION, LI6AI. - ACTION

FIG.27B

DURING FLIGHT-

ARMED

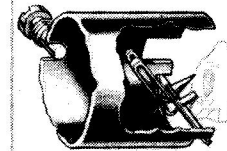
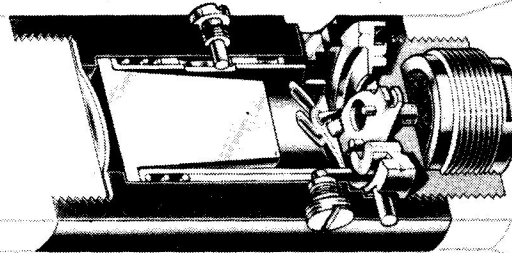
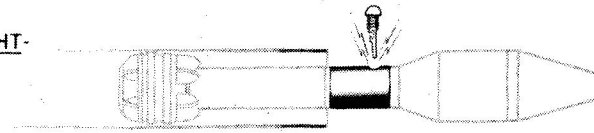

ARMED  
Rear view      Front view

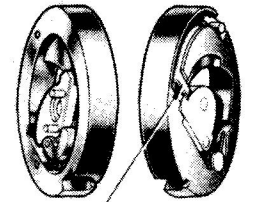

SHUTTER RETAINING  
SPRING

ON IMPACT

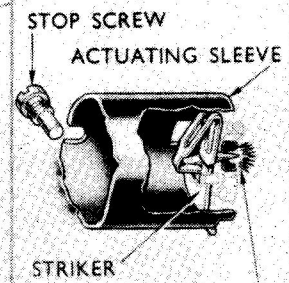
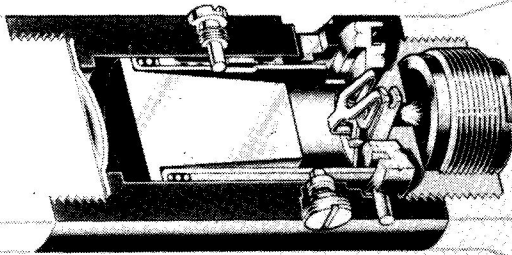

STOP SCREW  
ACTUATING SLEEVE  
STRIKER  
DETONATOR  
(2-8 GR. A.Z.)

ON IMPACT

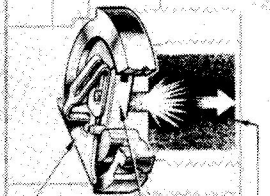

STRIKER  
SHUTTER  
MAGAZINE

**FUZE, PERCUSSION, LI6A1.**

**FIG.16A**

**COMPONENT PARTS**

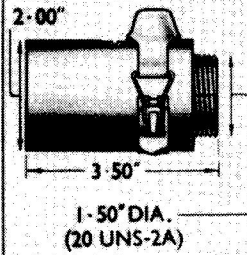
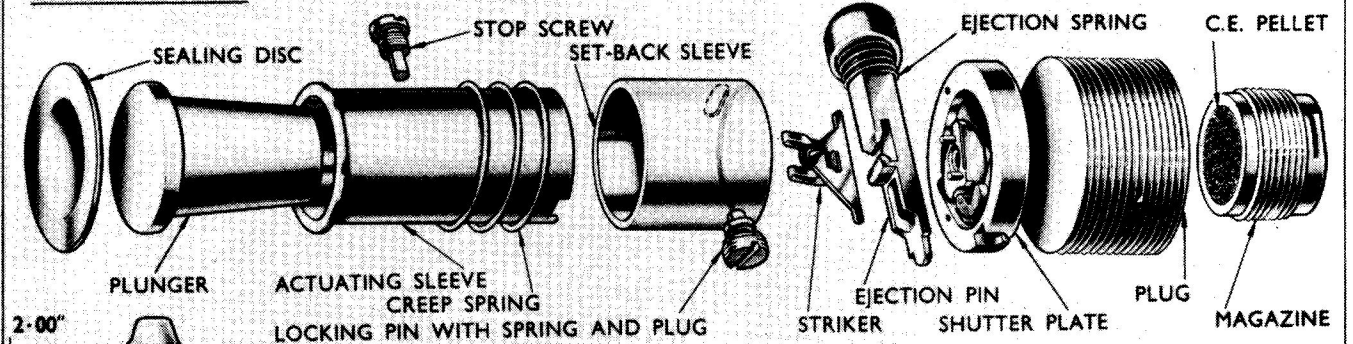

**GENERAL ASSEMBLY**

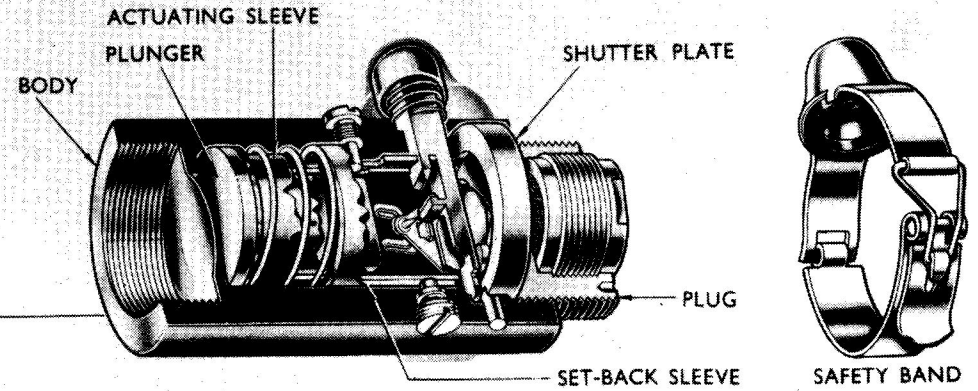



*Letters. Black. Catpat.*  
*Reg. No. 199.*

W.O.  
CODE No  
10229

**RESTRICTED**  
The information given in this document  
is not to be communicated, either  
directly or indirectly, to the Press or to  
any person not authorised to receive it.

USER HANDBOOK  
(PROVISIONAL)  
FOR THE  
LAUNCHER, ROCKET, 3·5-INCH U.K. M 20, MK.2  
1952

IA/MP 60

DIRECTOR OF INFANTRY  
WAR OFFICE

W.O.  
CODE No

10229

**RESTRICTED**

The information given in this document  
is not to be communicated, either  
directly or indirectly, to the Press or to  
any person not authorised to receive it.

USER HANDBOOK  
(PROVISIONAL)  
FOR THE  
LAUNCHER, ROCKET, 3·5-INCH U.K. M 20, MK.2

1952

IA/MP 60

DIRECTOR OF INFANTRY  
WAR OFFICE



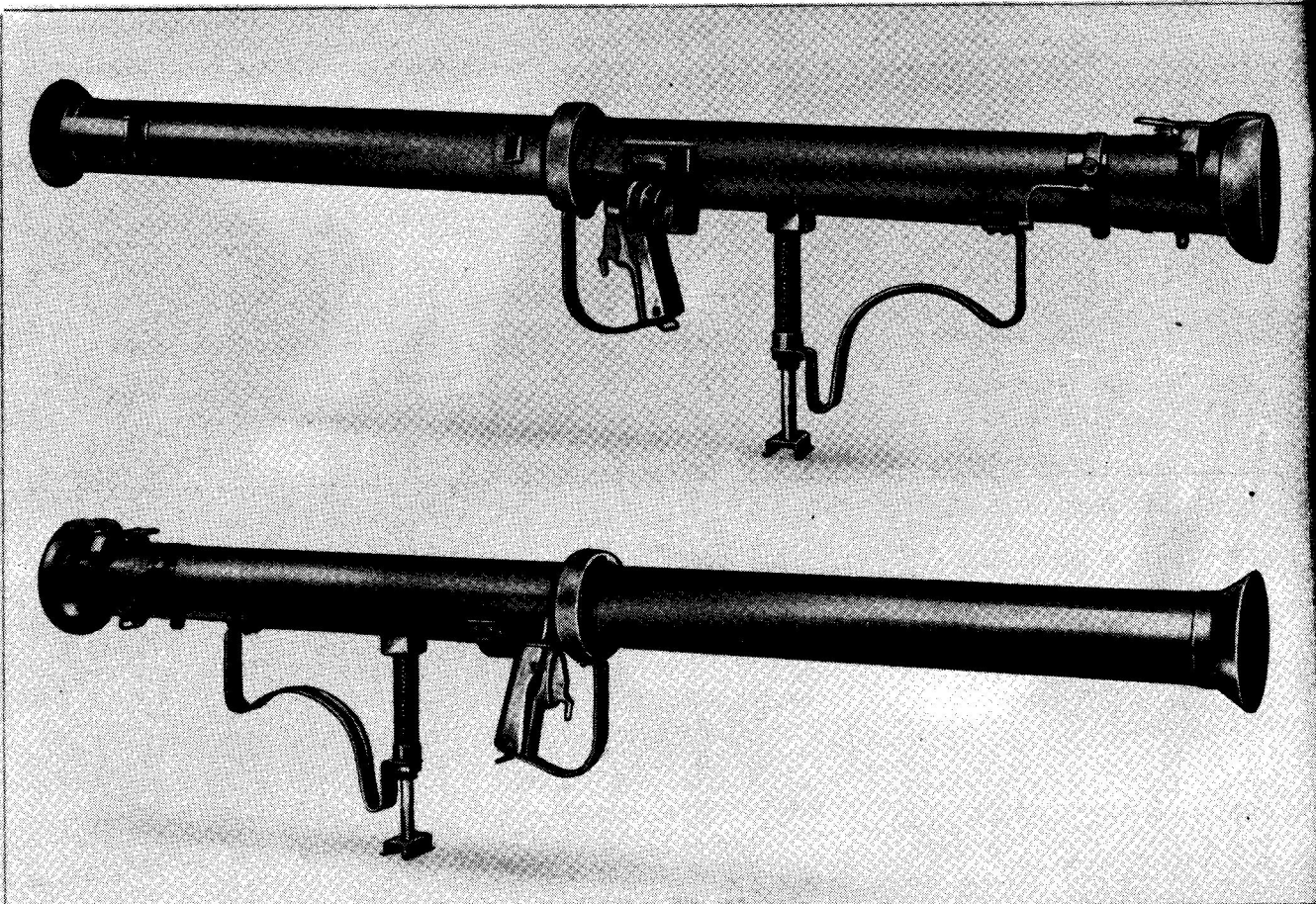

Frontispiece — 3.5 inch Rocket Launcher U.K. M20, MK. 2

3.5 INCH ROCKET LAUNCHER  
PART I GENERAL DESCRIPTION  
SECTION I THE LAUNCHER

1.0. Introduction

The 3.5 inch rocket launcher is a two piece tube which is open at both ends and has a smooth bore. Its function is to ignite the rocket and give direction to its initial flight. The weapon is fired from either the standing, sitting, kneeling or prone position. The firing operation is done electrically. There is no recoil, as pressure is not built up inside the tube. When the propellant is ignited, gas and flames are blown from the "breach" end and the area in rear of the launcher must be kept clear.

To reduce weight, the barrel is made of aluminium alloy and breaks down into two sections for ease in carrying.

Each launcher will be stamped with the Mark and serial number, year of supply and contractors initials. The position of the marking will vary with the different types of launcher.

The description which follows deals with the 3.5-in. Rocket Launcher U.K. M 20, Mk.2.

Units may also be issued with launchers of American manufacture. The main differences between the U.K. M 20, Mark 2, and those of American manufacture are dealt with at the end of this Section.

1.1. Tabulated data

|                              |     |     |     |     |     |     |     |     |             |
|------------------------------|-----|-----|-----|-----|-----|-----|-----|-----|-------------|
| Length of launcher assembled | ... | ... | ... | ... | ... | ... | ... | ... | 61 ins.     |
| Length of front barrel       | ... | ... | ... | ... | ... | ... | ... | ... | 30.25 ins.  |
| Length of rear barrel        | ... | ... | ... | ... | ... | ... | ... | ... | 31.625 ins. |
| Weight of launcher           | ... | ... | ... | ... | ... | ... | ... | ... | 12.1 lb.    |
| Weight of front barrel       | ... | ... | ... | ... | ... | ... | ... | ... | 3.5 lb.     |
| Weight of rear barrel        | ... | ... | ... | ... | ... | ... | ... | ... | 8.6 lb.     |
| Type of firing mechanism     | ... | ... | ... | ... | ... | ... | ... | ... | Electric    |

2.0. The barrel is in two parts and is joined together by three coupling lugs on the rear end of the front part of the barrel and a coupling nut on the front end of the rear part of the barrel (Fig. 1). The two parts are engaged by turning the front part through about 60 degrees in a clockwise direction, further rotation being prevented by the narrowing of the grooves in which the lugs work. The barrel joint is secured by a screw which exerts a jamming action against the inclined face of one of the lugs and is operated by a barrel locking lever.

For ease in carrying, the barrel parts are uncoupled and secured to each other side by side (Fig. 2). The attachment in the carrying position is by means of a hook on the front barrel and an eye on the rear barrel to secure one end, and a latch bolt at the other end.

3.0. The breech guard. The breech end of the rear barrel is shaped to form a breech guard (Fig. 3) to facilitate loading. The guard is cut away to permit movement of the blade of the contact latch assembly.

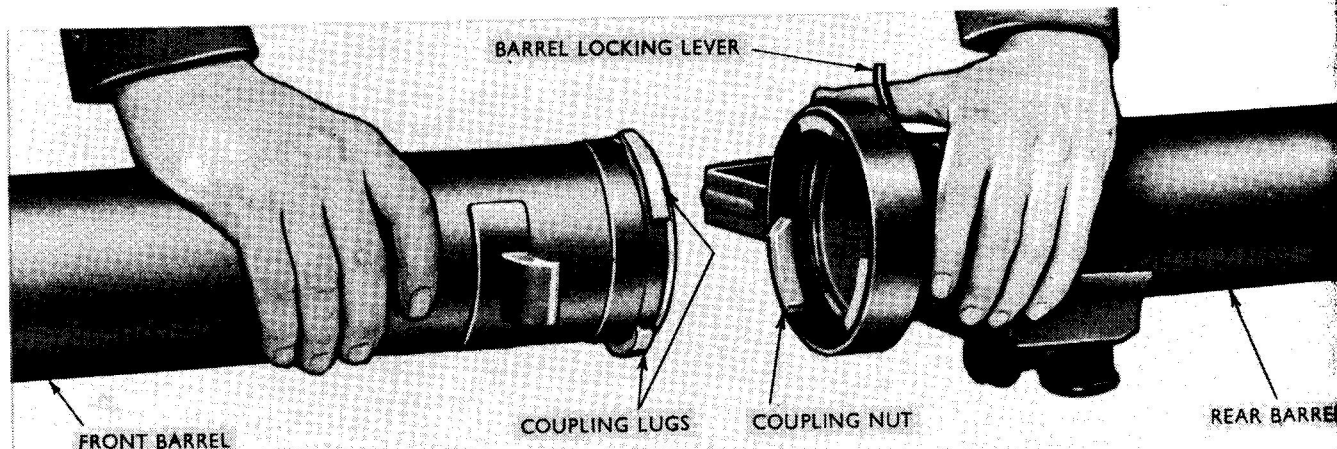

Fig. 1 Assembling of Barrel

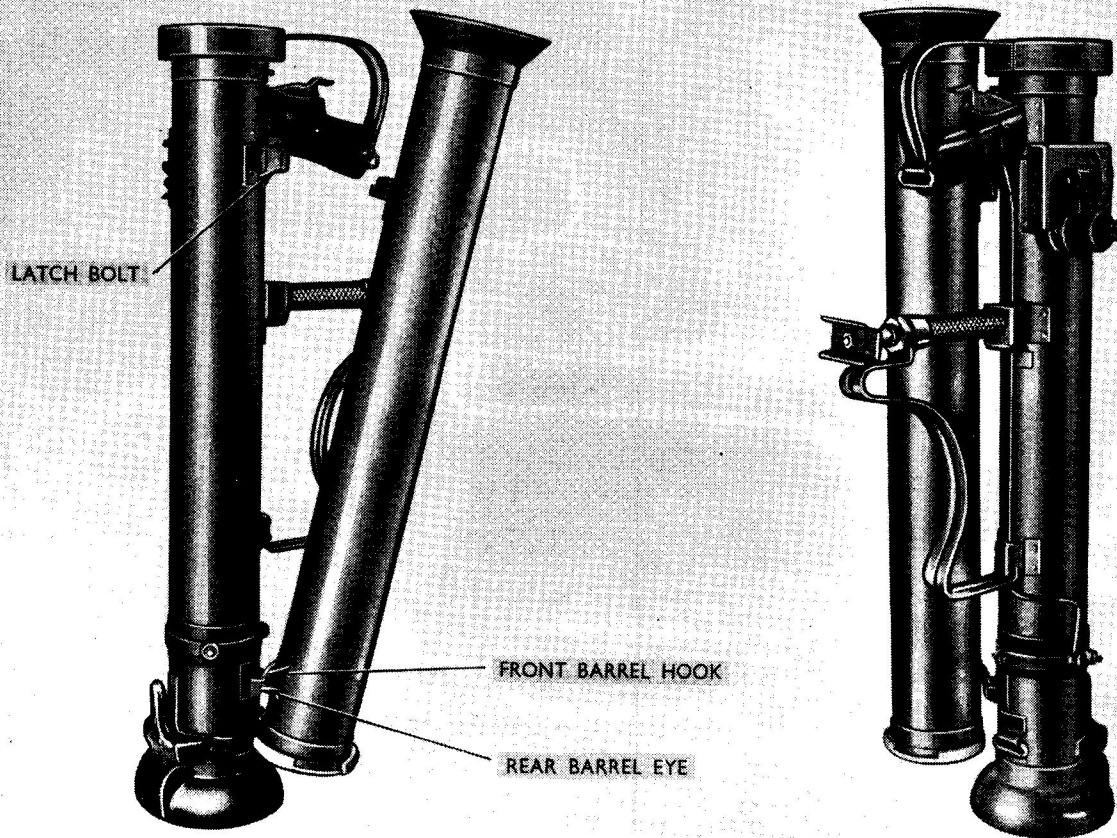

Fig. 2 The Barrel-Carrying Position



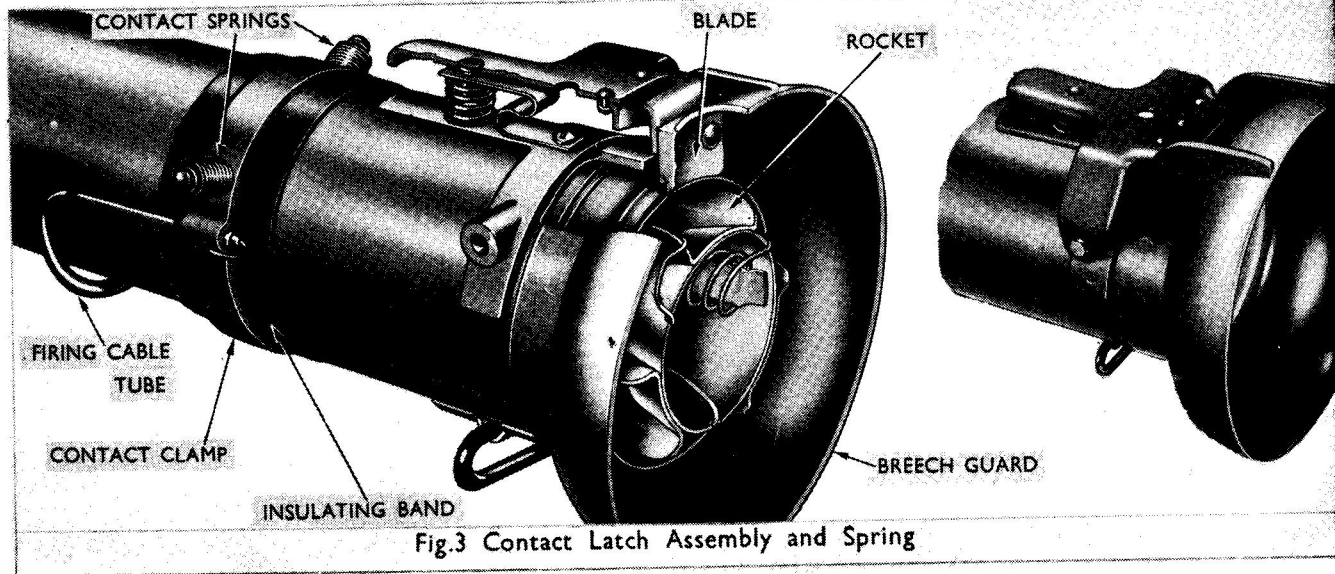
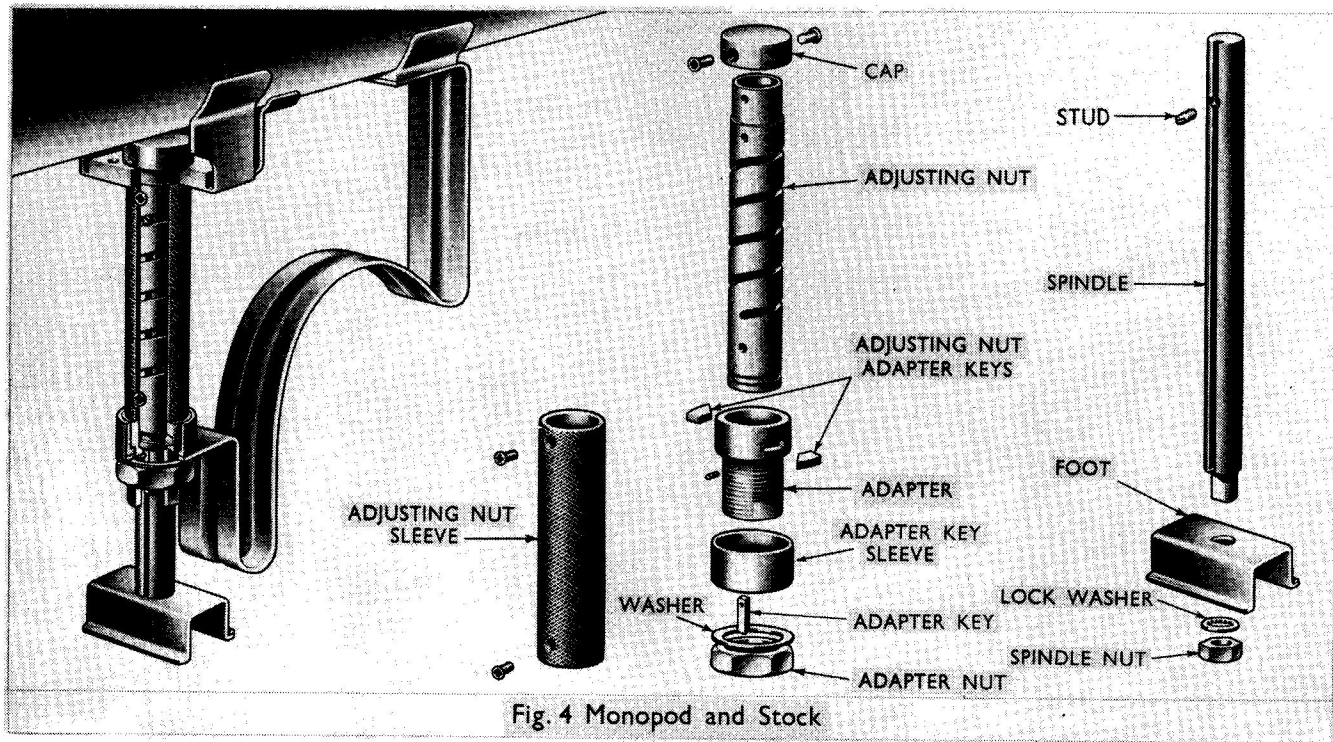

Fig.3 Contact Latch Assembly and Spring

4.0. The contact latch assembly (Fig. 3) is fitted in front of the brech guard on the rear barrel. It pivots on lugs fitted one on each side of the barrel. The rear of the assembly protrudes through an opening in the brech guard and engages the rear of the rocket to hold it in its proper firing position in the launcher. The contact between the blade and the rocket provides the earth to complete the firing circuit. The rear end of the assembly is kept depressed by a spring fitted under the forward end. When the rocket is loaded or unloaded, the forward end of the assembly is pressed down, and pivoting on the lugs on the side of the launcher, the rear is lifted clear of the brech guard.

5.0. The contact springs (Fig.3) are fitted one on each side of the rear of the barrel and provide a quick means of connecting the bare end of a contact wire which is coloured blue and attached to the rocket tail. Both springs are mounted on a metal contact clamp so that either gives an electrical connection. The clamp fits over an insulating band which prevents contact between it and the barrel. The electrical connection between the clamp and the firing mechanism is an insulated wire which runs through an aluminium firing cable tube to protect it from damage.

6.0. The Monopod and stock (Fig.4) are attached to two lugs formed on the underside of the rear barrel and located in front of the contact clamp. It rests on a foot and is adjustable for height by means of an adjusting nut. The adjusting nut is provided with a spiral slot which fits over the spindle of the monopod. Over the adjusting nut is secured a sleeve the rotation of which causes the spiral to move over a stud in the spindle enabling it to be extended or retracted at will.



7.0. The sight bracket (Fig.5) is on the left side of the rear barrel part, just in front of the monopod. To the top part of the bracket a range plate is secured by means of two adjusting screws. On the plate is marked a range scale with one setting marked 0 to 450 and other settings indicating every 50 yards from 500 to 900, the hundreds being numbered from 5 to 9. Notches along the scale are engaged by a projection on a pointer to hold the sight setting. Elongated slots in the plate provide a means of adjustment when zeroing sights.

The bottom part of the bracket has pinned to it the range plate indicator and a yoke to which is attached a reflecting sight. The attachment of the sight to the yoke is by a stud which forms a hinge to allow the sight to be folded against the launcher when in the carrying position. Fitted to the hinge stud on which the sight pivots is a ball detent which holds the sight when it is swung to the carrying or firing position. The hinge stud has an index mark for reading a sight testing scale on the yoke through which it fits.

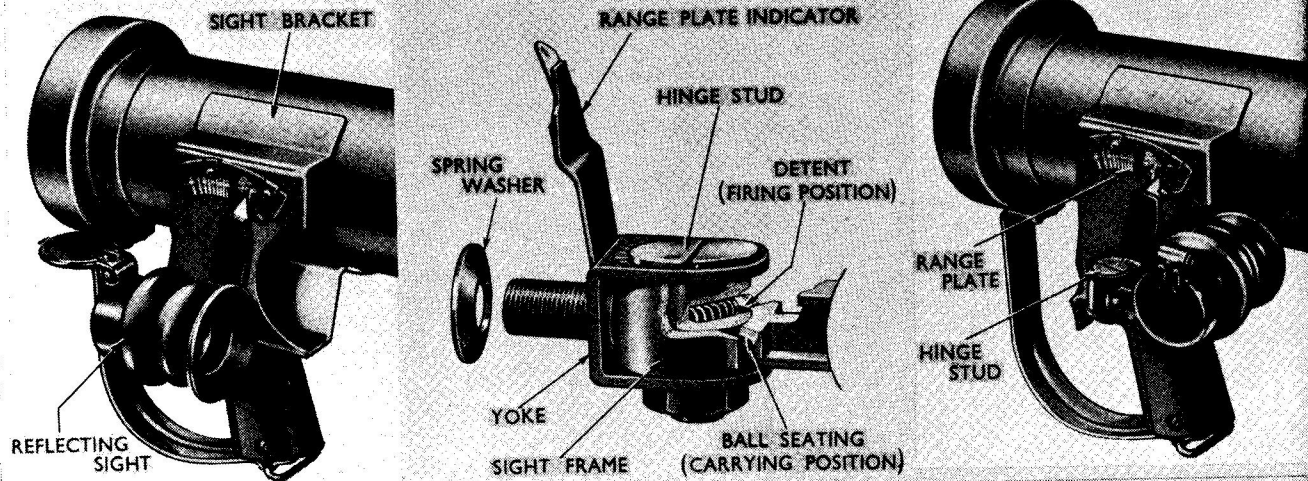

Fig. 5 Sight Bracket and Reflecting Sight

8.0. The reflecting sight (Fig.5) consists of a single lens and a graticule fitted into a housing, the two being separated by a metal spacer.

The lens, which fits into the front of the housing is protected by a hinged metal cover and to the rear of the housing is fitted a rubber-eye-guard. The sight has no magnification.

9.0. The graticule (Fig.6) is marked with a single broken vertical line, and five broken horizontal lines.

Each section of the vertical line, and the space between sections represents 50 yards.

The horizontal lines are marked in hundreds of yards, and for ranges up to 400 yards the line corresponding to the estimated target range is laid on the target.

The "lead" required for targets crossing the line of fire is obtained by laying that part of the horizontal line which corresponds with the estimated target speed on to the target.

The line marked 0 on the graticule is sometimes referred to as the normal line.

This is known as a ladder type graticule.

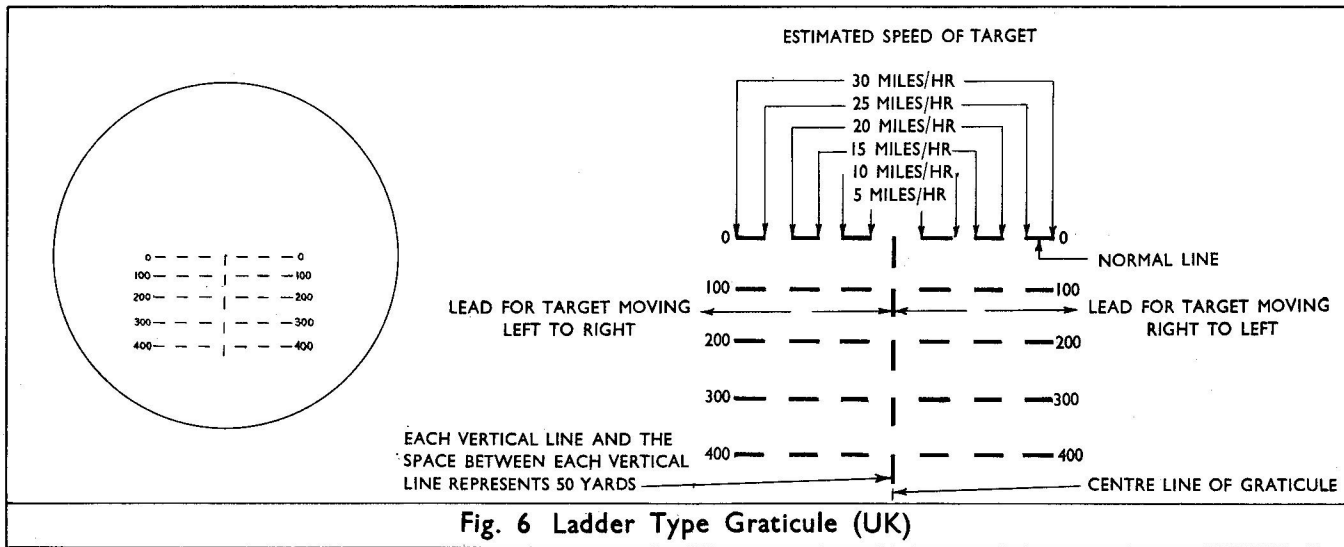

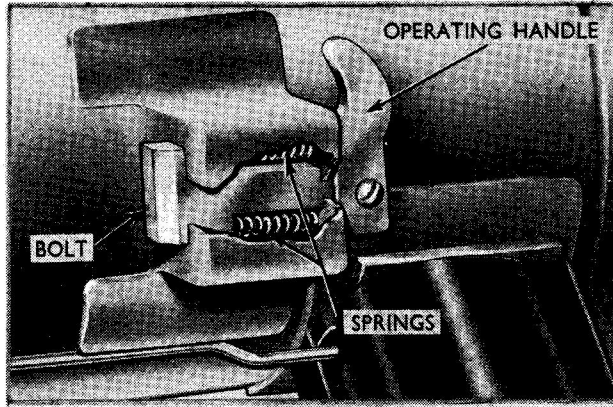

Fig. 7 Latch Bolt Assembly

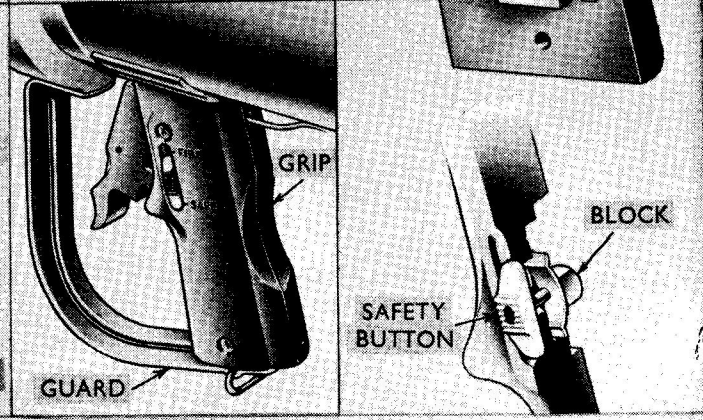
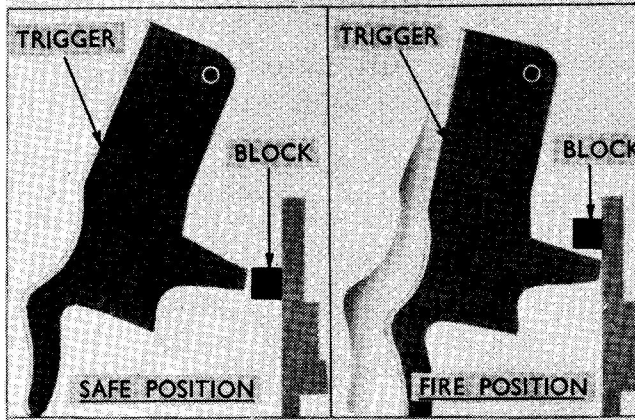
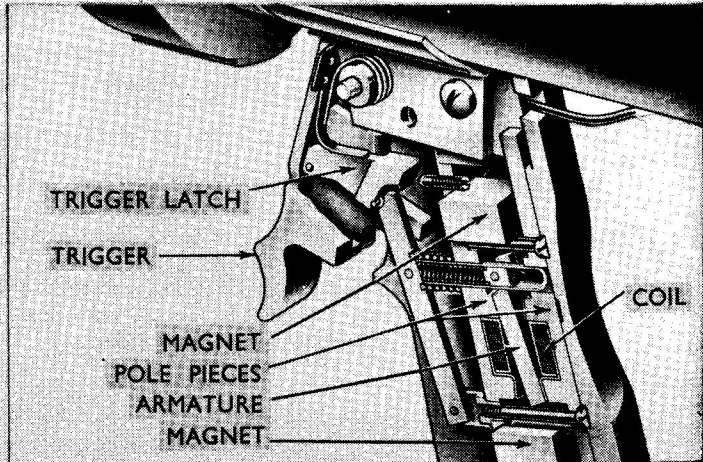

Fig. 8 Firing Mechanism

10.0. The latch bolt and operating handle (Fig.7) are located on the right side of the rear barrel behind the trigger grip. The bolt engages a bracket on the front barrel and is used to secure the two parts of the barrel in the carrying position. The bolt and its two springs are housed in a frame and are operated by a small handle which when moved to the front will release the bolt from the bracket on the front barrel.

11.0. The firing mechanism (Fig.8) is housed between the trigger grips and secured to the underside of the rear barrel. The current generator is a magneto which has a powerful permanent magnet at the top and at the bottom for magnetizing the pole pieces. Between the poles is a coil of wire through the middle of which a soft iron armature is made to rock with a rapid snap action when the trigger is squeezed. The rocking movement induces in the coil the current for firing the rocket. A spring returns the trigger to its normal position after it has been released.

The trigger is protected by a metal trigger guard with a loop to take one end of a web sling.

12.0. The safety button (Fig.8) is located on the left side of the trigger grip in a position convenient for manipulation by the thumb of the right hand. The button has two positions, the upper marked FIRE and the lower marked SAFE. With the switch in the upper position the trigger can be operated to fire the launcher but when set to the lower or SAFE position the trigger is prevented from moving by a block fitted to the inside of the button axis pin.

13.0. The barrel locking lever (Fig.9) is located at the front and on the right side of the rear barrel. It operates the locking lever screw which locks the joint of the front and rear barrel. When assembling the front and rear barrel, or when breaking the launcher down to the carrying position, the lever is raised to hold the screw in the unlocked position.

When released, the lever is returned and held by a spring in its locked position.

M.P.60

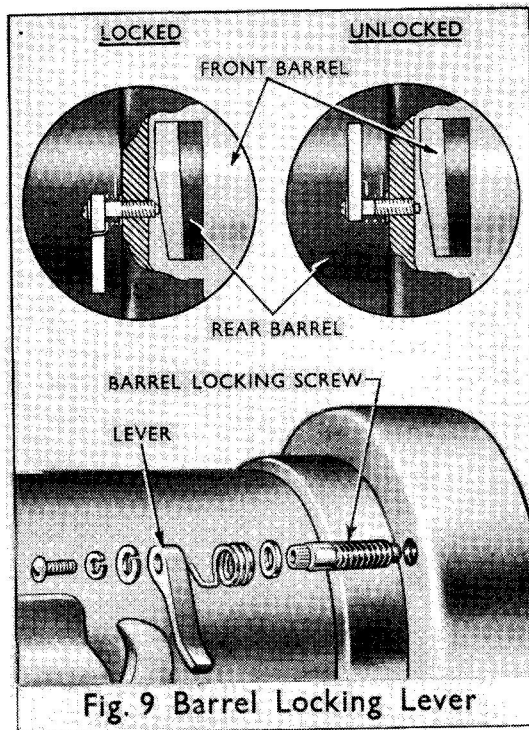

Fig. 9 Barrel Locking Lever



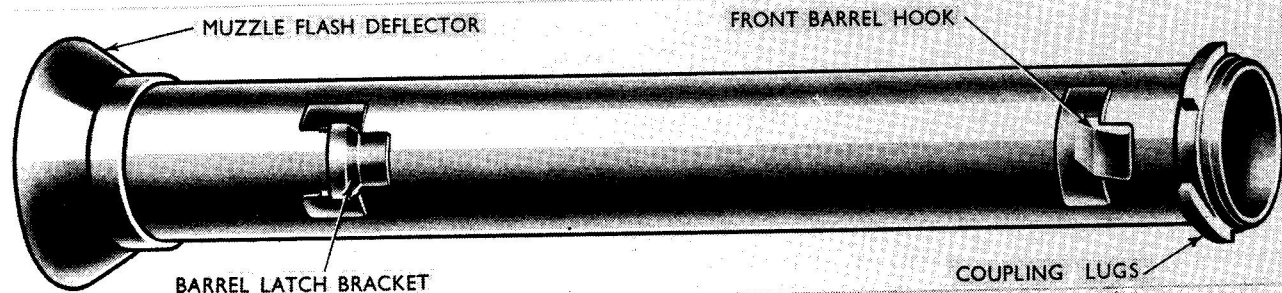

Fig. 10 Front Barrel

14.0. The front barrel (Fig.10) is fitted at its rear end with three inclined lugs mating with three internally formed lugs on the rear barrel and requiring about 60 degrees clockwise rotation to engage the two. In the locked position, the two portions of the barrel should be firmly secured and there should be no play. A hook in front of the threaded portion provides the means of attachment to an eye on the rear barrel part when the launcher is in the carrying position.

Two raised portions may be found on the front barrel part of some models. They were required when a bipod was fitted and are not now used.

15.0. The barrel latch bracket (Fig.10) is fitted to the side of the front barrel near the muzzle end. In conjunction with the latch bolt on the rear half of the launcher, it secures the launcher in the carrying position.

16.0. The muzzle flash deflector (Fig.10) which is formed at the front of the barrel, diverts blast and particles of unburned powder which might otherwise strike the user.

17.0. 3.5 inch Rocket Launcher M.20 (U.S.A. manufacture)  
This launcher differs from the U.K. M.20 Mark 2 as follows:-

The muzzle deflector, breech guard and barrel coupling are fastened to the barrel by screws. The monopod and stock are secured to the rear barrel by bands.

18.0. 3.5 inch Rocket Launcher M.20 B.1 (U.S.A. Manufacture)  
This launcher differs from the U.K. M.20 Mk.2 as follows:-

The muzzle deflector, breech guard, sight bracket support, and barrel coupling are cast integral with the barrel.

The attachment of the monopod, and stock, are similar to the U.K. M.20 Mk.2.

19.0. Variations in graticules  
The following graticules may be found on American launchers:-

19.1. Ladder (Fig.11) The position of the ladder graticule on U.S.A. Launchers differs from that on U.K. Launchers. On U.S.A. launchers the horizontal line marked 200 is in the centre of the sight. On U.K. launchers the horizontal line marked 0 is in the centre of the sight. The aiming and sight setting procedure is the same with both types.

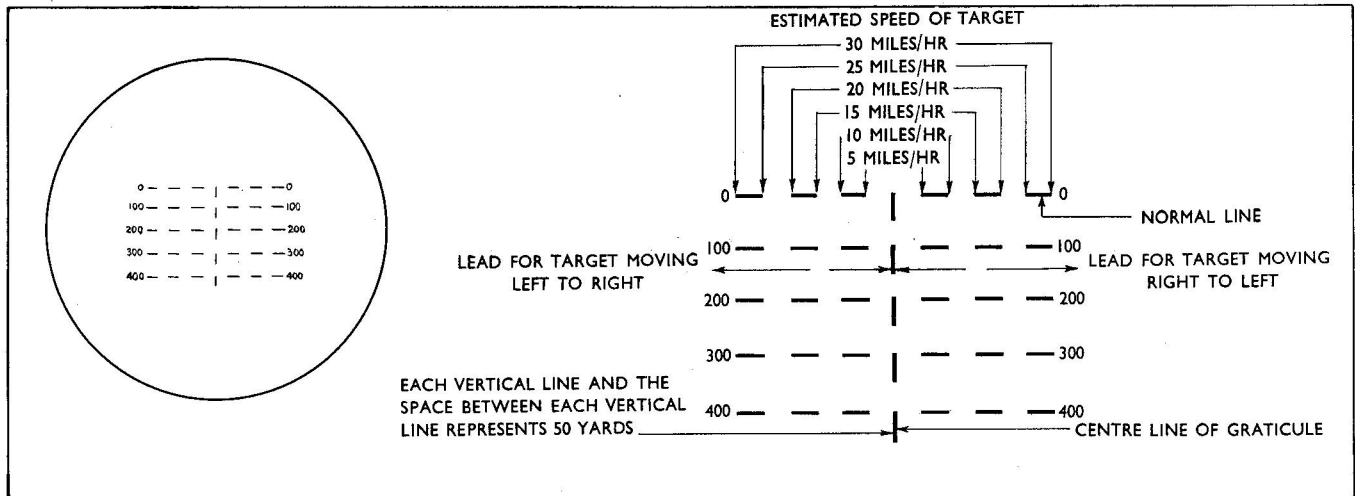

Fig. 11 Ladder Type Graticule (US)



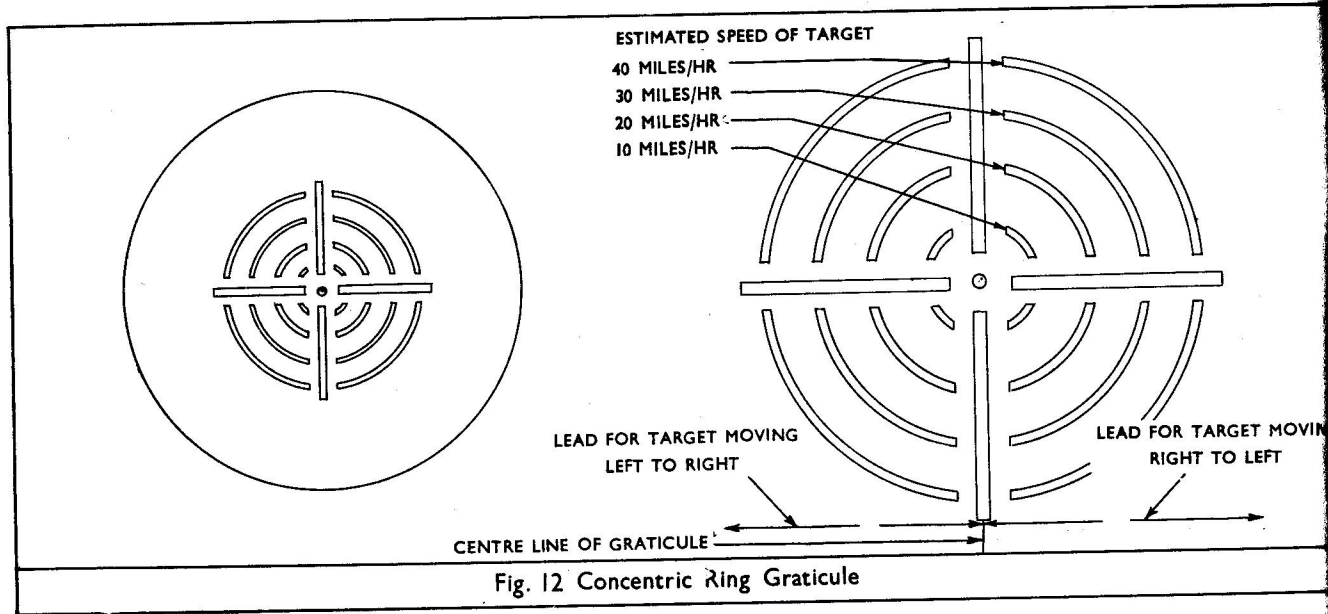

Fig. 12 Concentric Ring Graticule

19.2. Concentric ring (Fig.12) Has a vertical and horizontal line, and rings spaced to give the necessary lead for targets moving across the line of fire.

This graticule is used with a range plate marked from 0 to 9 to indicate the range in hundreds of yards.

19.3. Elliptical (Fig.13) Has a vertical and horizontal line and an ellipse.

Short vertical lines on the horizontal axis are used to give the necessary lead to the launcher when laying on targets moving across the line of fire.

This graticule is used with a range plate marked 0 to 9 to indicate the range in hundreds of yards.

20.0. Firing Mechanism

A firing mechanism which differs from that described at para. 11, may be found on some M.20

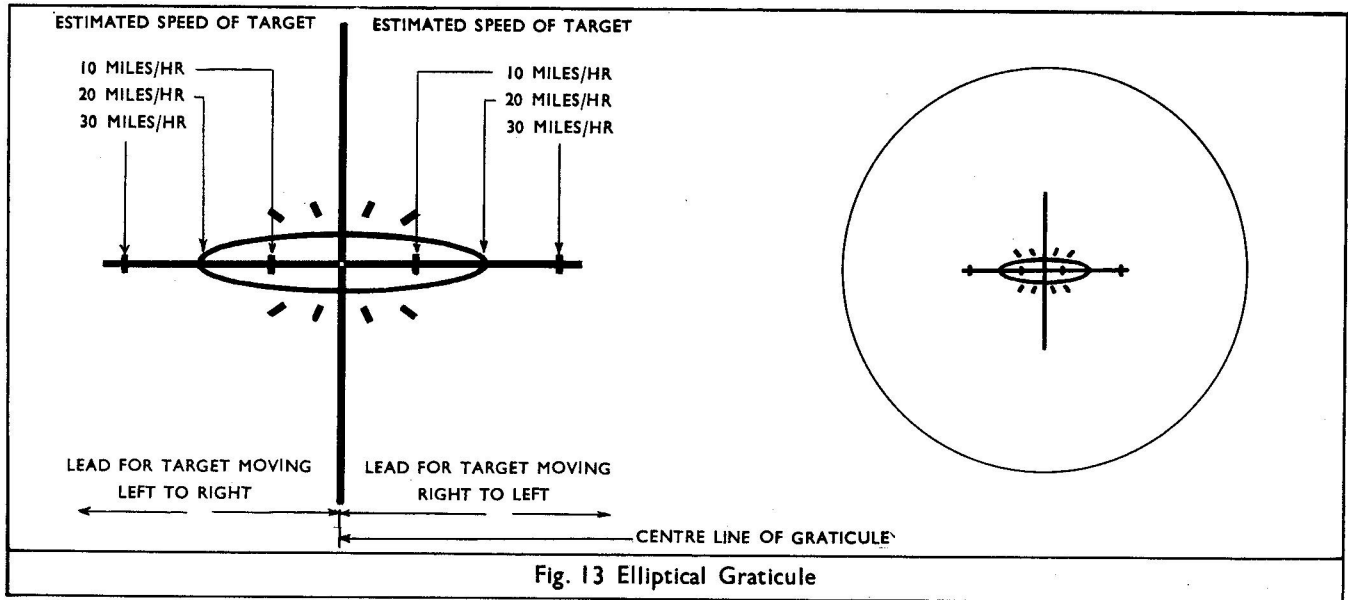

Fig. 13 Elliptical Graticule

launchers. It can be identified by the position of the safety switch which is on the rear of the trigger grip. The upper position of the switch is marked **SAFE**, and the lower position **FIRE**, which is the reverse of the safety button described at para. 12.

20.1. The following differences should also be noted:-

20.1.1. Current is generated when the trigger is squeezed AND when the trigger is released. If the rocket does not fire when the trigger is squeezed, it may fire when the trigger is released.

20.1.2. When the safety switch is set at **SAFE**, the trigger can be operated but the current is short circuited and does not pass to the rocket.

20.1.3. The current output is about one third of that obtained with the mechanism described at para. 11.

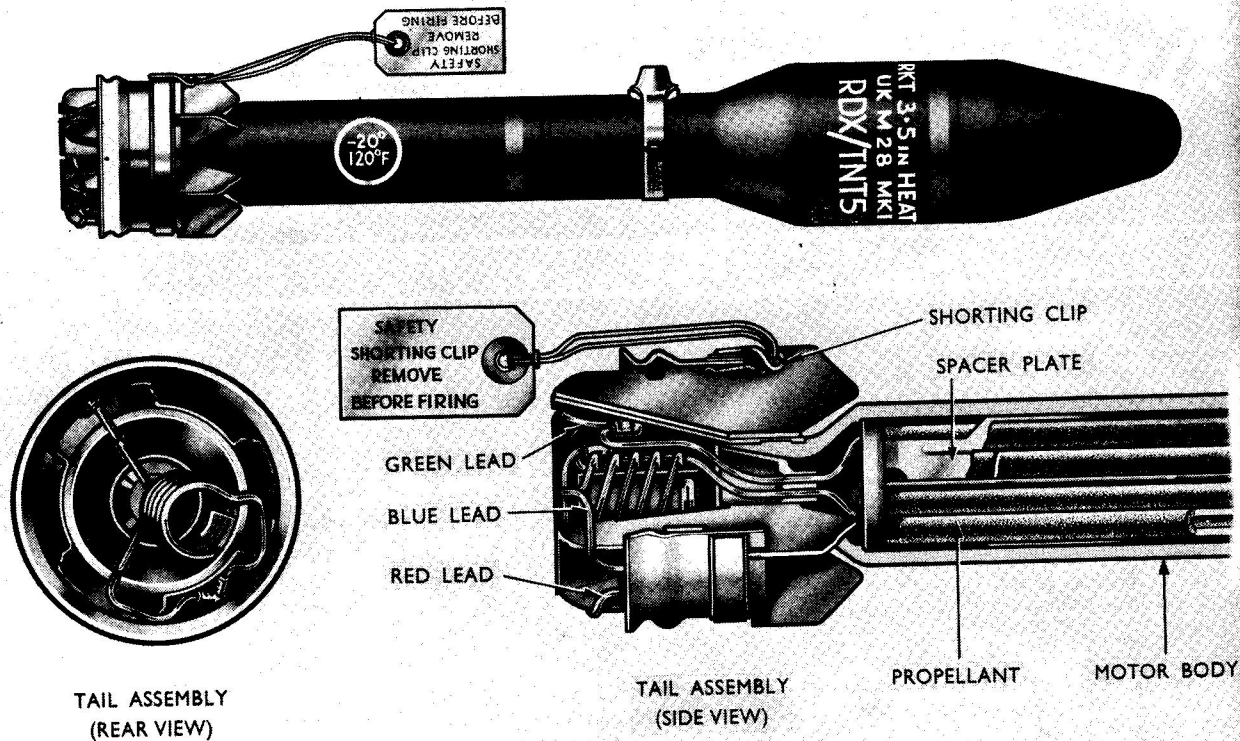

Fig. 14 Rocket, H.E.A.T. 3.5 inch

PART I GENERAL DESCRIPTION

SECTION 2. THE ROCKET

21.0. Introduction

The rocket is issued assembled and is loaded into the launcher as a unit. It consists of a rocket head, a fuze and a motor, to the rear of which the tail assembly is attached. The complete rocket is shown at Figs. 14 and 15.

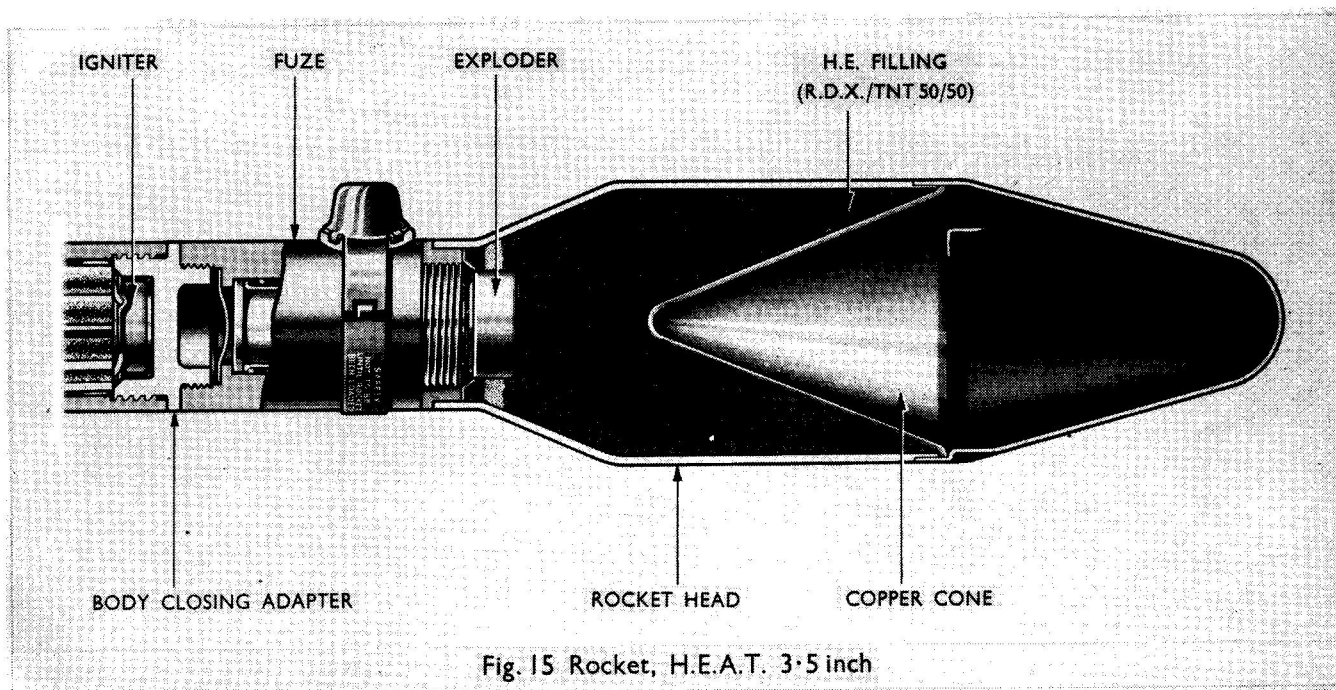

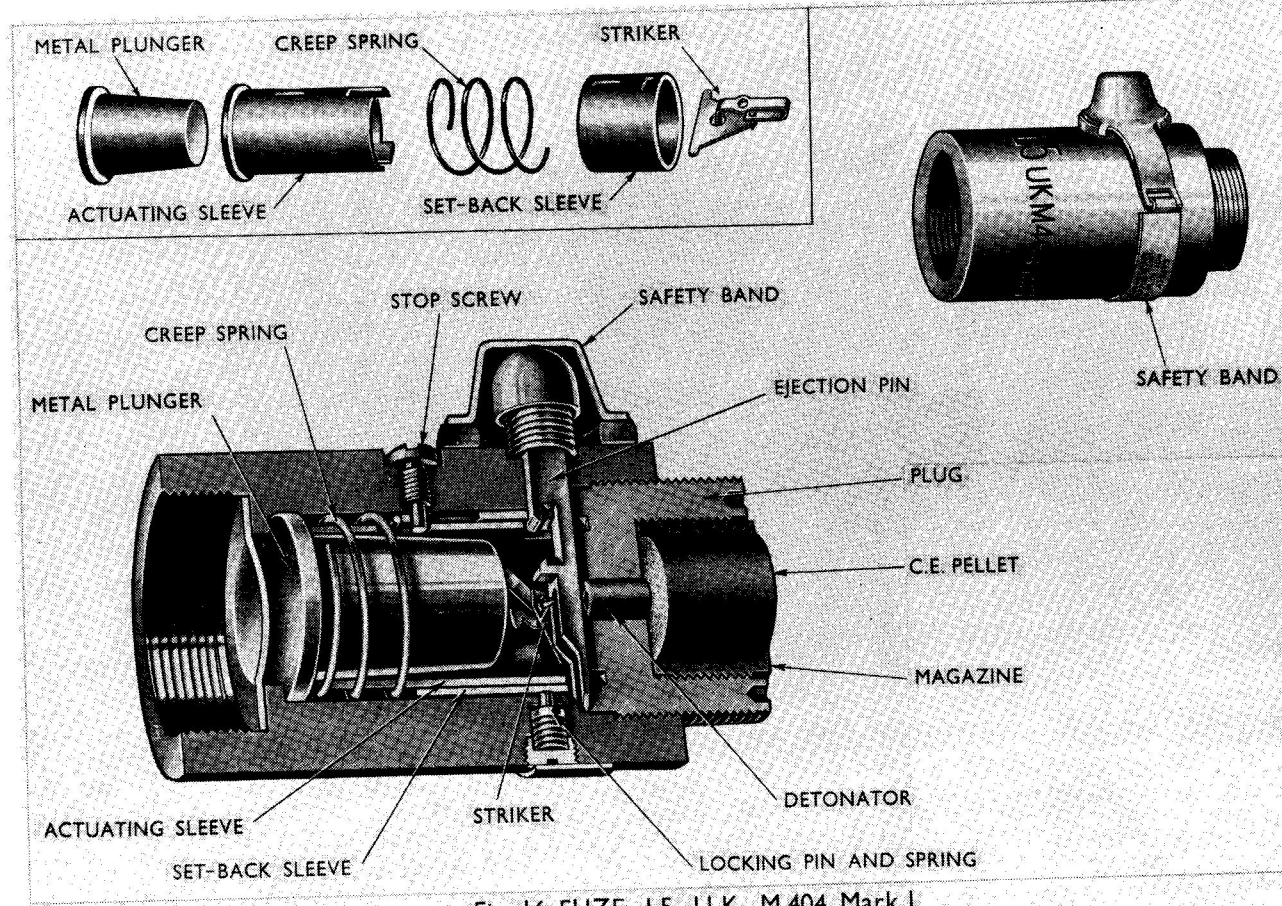

Fig. 16 FUZE, L5. U.K. M404 Mark I

22.0. The head (Fig.15) is of steel, cylindrical in shape with a diameter of 3.5 inches. The front is shaped to form a ballistic head and at the rear, it tapers to a 2 inch diameter. The head contains an internal copper cone which shapes the H.E. filling. The rear of the rocket head is fitted with a base which is threaded internally for attachment of the fuze.

23.0. The fuze (Fig.16) is a base percussion type, cylindrical in shape, with an external diameter of two inches. The front end is closed by a plug which is threaded externally to take the rocket head and internally the magazine containing a C.E. pellet. The rear of the fuze body is threaded internally to receive a body closing adapter on to which is screwed the rocket motor. Internally the fuze is fitted with a metal plunger, an actuating sleeve, a set back sleeve, creep spring and striker. Passing into the fuze from the outside is an ejection pin, and adjacent to it a stop screw. The side of the fuze opposite to the ejection pin is fitted with a locking pin and spring.

The ejection pin passes through the fuze body and is held in position by a safety band which encircles the body. The pin prevents any movement of the internal parts during storage and handling, and masks the detonator from the striker. The safety band is removed just prior to the rocket being finally pushed home into the launcher, and under the influence of its spring the ejection pin moves out from the safe position to the locked position. The fuze cannot arm when the ejection pin is in either of these two positions.

As the rocket enters the launcher the ejection pin is depressed to the mid position. The setback sleeve is then free to move on firing, thus allowing the pin to be ejected by the spring as the rocket leaves the launcher. The fuze is then armed.

24.0. The motor (Fig.17) consists of a body, spacer plates, propellant, igniter with connecting leads, and attached to the rear is the tail assembly.

25.0. The body, is a steel tube with an outside diameter of two inches, which is threaded internally at the front end to screw on to the body closing adapter. The rear of the body is tapered to form a nozzle, the outside of the tapered portion forming part of the seat for the tail assembly. A plastic closure plug fits into the nozzle and through the plug pass two leads from the igniter.

26.0. The two spacer plates (Fig.18) fit inside the body to form four compartments for the propellant. A metal grid is attached to the plates at the end nearest the tail. (Fig.17). Fitted into each compartment formed by the spacer plates are three sticks of propellant.

27.0. The igniter (Fig.19) consists of a short cylindrical plastic case which fits inside a recess in the body closing adapter. The case contains a wire bridge surrounded by black powder. Two leads are connected to the igniter and run down through the body of the motor parallel to the propellant and

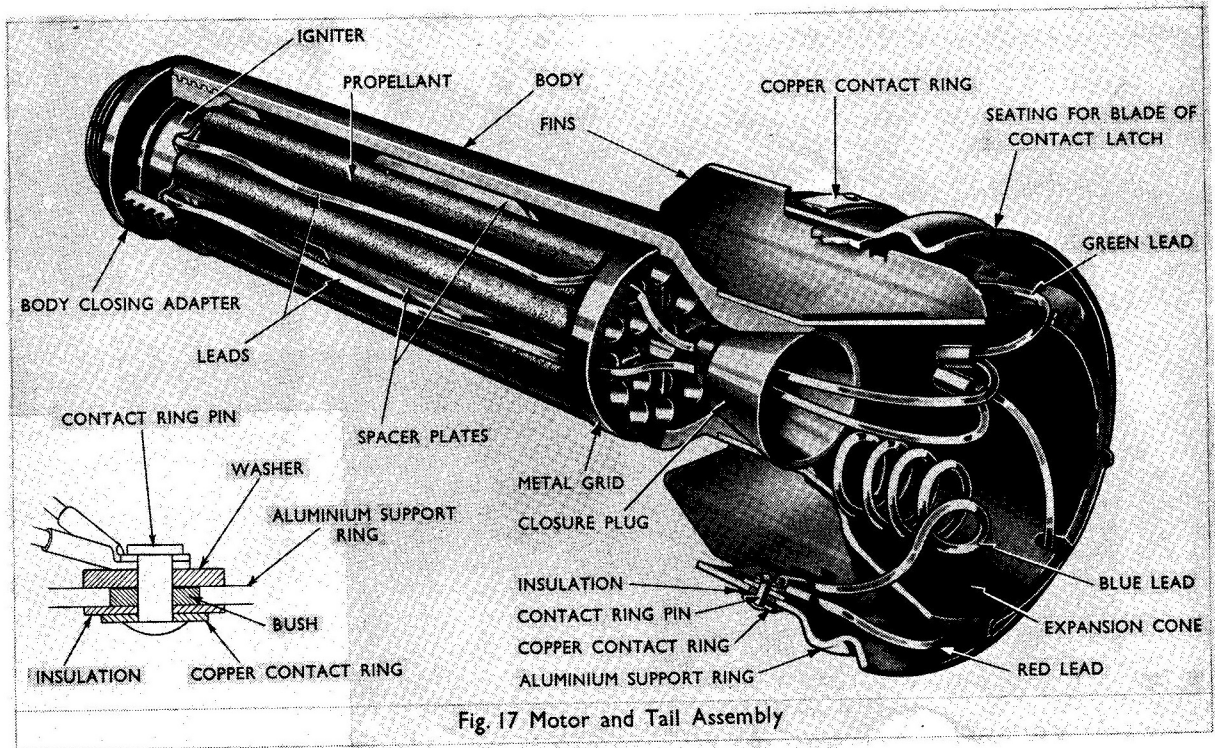

out through the plug in the nozzle (Fig.17). To the end of one lead from the igniter is attached a wire with red insulation and to the second lead from the igniter is attached a wire with green insulation.

The red lead is connected by a pin to a copper contact ring which fits around the outside of the fins. To the same pin is secured a blue lead which is coiled into the nozzle and secured by adhesive tape. Its position is such that it can be easily pulled out to its full length and attached to one of the contact springs on the launcher. The free end of the blue lead is stripped of insulation.



for a short distance and then covered with a short piece of plastic tubing which insulates the stripped end during transport and handling.

The green lead is connected to the aluminium support ring and provides the earth return for the circuit.

28.0. The tail assembly (Fig.17) consists of an expansion cone which is fitted to the motor tube at the nozzle, three double-bladed fins which are welded to the outside, and a band built up of three rings which encircles the fins. The innermost ring, is an aluminium support ring; the outer, a narrow copper contact ring, and separating the two is a ring of insulating material. The support ring is grooved to provide a seating for the blade of the contact latch and is not painted. When issued, the rocket is provided with a shorting clip which fits over the unpainted section at the front of the aluminium support ring and forms a connection between the aluminium support ring and the copper contact ring (Fig.14). This clip should always be in position when the rocket is stored or transported and is removed when the rocket is prepared for loading. Secured to the clip is a label marked "Safety shorting clip. Remove before firing."

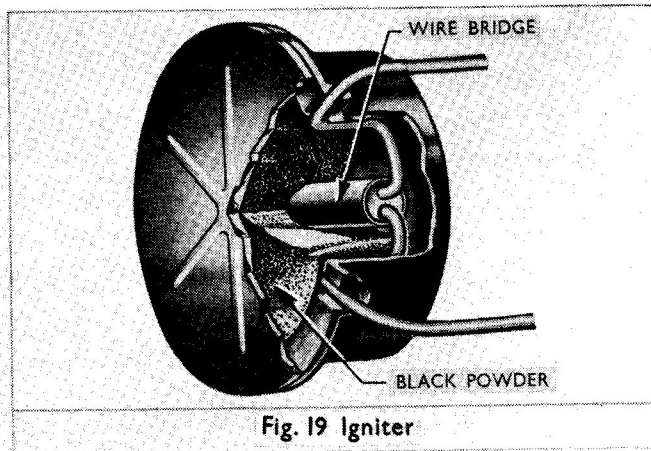
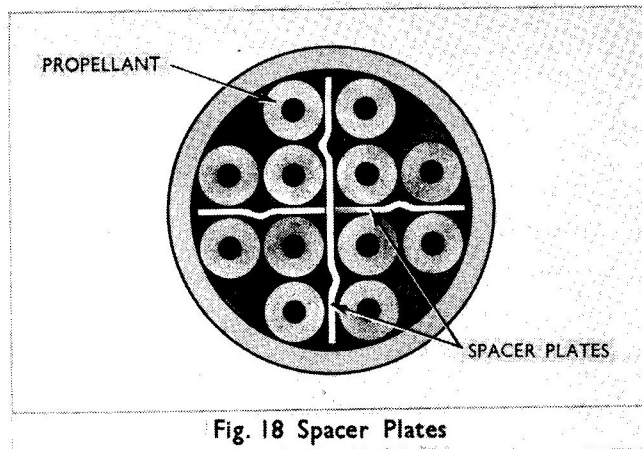



The shorting clip acts as a safety device during storage and transit by providing a short circuit to prevent current passing through the igniter and firing the rocket.

29.0. Rocket Practice 3.5-inch

This rocket is the same size and weight, and has the same flight characteristics as the service rocket. The head is usually of cast iron but may be of steel and is filled with an inert substance to give the required weight.

30.0. Fuze Practice

This is an inert fuze used with the Practice Rocket. It incorporates an ejection pin and safety band so that the loading procedure is similar to that required with the service rocket.

PART 2 OPERATION

SECTION 1 THE LAUNCHER

31.0. Assembling the launcher

The barrel parts are disengaged from their carrying position by releasing the latch bolt which enables the front and rear barrel parts to be separated. The barrel locking lever is raised and held in its unlocked position, and the coupling lugs on the front barrel turned in the nut on the rear barrel (Fig.1). The locking lever is then released and the launcher is ready for loading.

32.0. Loading

Before loading, ensure that the bore is clear and set the safety button to "SAFE". The end of the blue contact wire is taken out of the expansion cone at the rear of the rocket and the wire pulled straight back to uncoil it. The shorting clip is removed from the tail assembly. The front end of the contact latch assembly is depressed to allow the head of the rocket to be inserted into the rear of the barrel. After the head has been partially inserted into the launcher barrel, the contact latch is released to hold the rocket firmly, and the safety band is then removed. The front end of the contact latch is again depressed and the rocket is then pushed carefully into the barrel until the contact latch blade engages a groove on the support ring at the rear of the rocket. The insulating tube is pulled back to expose approximately half an inch of the wire, and the uninsulated portion engaged between the coils of either of the contact springs. The launcher is then ready for firing.

32.f. The following points should be noted:-

32.f.f. The loader must never stand directly behind the launcher.

32.f.2. The loaded launcher must not be jarred. When loaded into the launcher, the ejection pin of the rocket is held depressed and the rocket is prepared for arming. If the launcher is dropped so that the breech guard strikes the ground first, the shock may move the setback sleeve of the fuze sufficiently to lock it into its rearward position. If the rocket is thrown forward into the launcher by the fall, it should be pulled back to the firing position and no further, and the rocket fired.

32.1.3. Care must be taken that the bare end of the wire does not touch any other part of the launcher when held in the contact spring as this may short circuit the firing current and cause a misfire.

### 33.0. Sighting (Ladder graticule)

The lens cover is opened and the sight swung out into the firing position. For ranges up to 450 yards the range plate indicator is set to the 0 to 450 marking and the horizontal line of the graticule corresponding to the estimated target range is used for laying. If the range is greater than 450 yards the range plate indicator is set to the estimated range, and the zero line of the graticule used for laying.

For stationary targets, the intersection of the horizontal line corresponding to the estimated range, and the vertical line is laid on the centre of the target mass. At short ranges the point of aim may be shifted to the most vulnerable spot on the target.

For targets moving directly across the line of fire, the range plate indicator is set at the correct position on the range plate and that portion of the selected horizontal line which gives the correct lead is laid on the centre of the target mass. The vertical line should be in front of the target.

For targets which are moving directly towards or away from the launcher, the range plate indicator is set at the correct position on the range plate and the vertical line laid on the centre of the target mass. If the target is approaching, lay the selected horizontal range line on the bottom of the target. If the target is moving away, lay the selected horizontal range line on the top of the target.

### 34.0. Firing (Fig.20)

To fire the rocket, the safety button is moved to "FIRE" and the trigger squeezed. The current passes from the magneto coil by lead to the clamp at the rear of the launcher on which the two contact springs are mounted. The blue lead attached to one of the contact springs leads to the rocket tail through the red extension and then to the igniter in the rocket. The return path of the current is via the second igniter lead to the green lead at the rocket tail and through the fins and the contactor latch. The passing of the current through the igniter fires it.

### 34.1. Caution

34.2. Before firing the launcher, the area behind it within a distance of 25 yards must be clear of personnel or inflammable material. The danger zone is a triangular area with a base and height of 25 yards (Fig.21).

34.3. When firing from the prone position, the user must be at an angle of not less than 45 degrees to the line of fire to avoid injury by the rear blast of the weapon.



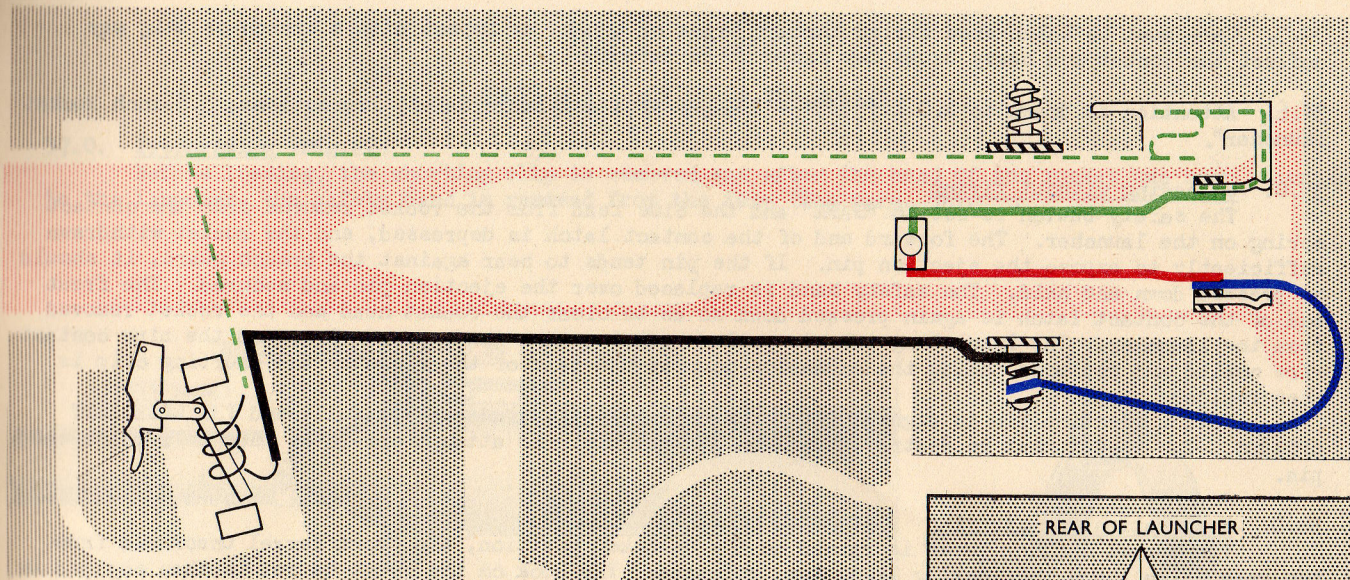

Fig. 20 Firing Circuit

It is important that this is also borne in mind by the user when following a target, so that the feet and legs are always clear of the blast.

34.4. The loader and firer should take special precautions when firing rockets below a temperature of 60°F., to protect the eyes and face from particles of unburned propellant. An improvised face-mask made of a gas eye shield and light canvas cloth, or an issue face mask should be used.

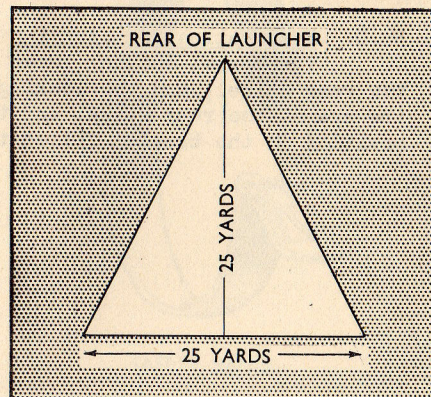

Fig. 21 Danger Zone

34.5. Care must be taken when firing through trees or brush, as impact with a branch or twig may deflect the rocket and heavy brush may cause it to detonate.

34.6. Attention is drawn to A.C.I.157/5† - "Danger area and Range Safety Precautions, 3.5-inch Rocket launcher".

35.0. Unloading without firing

The safety button is set to "SAFE" and the blue lead from the rocket removed from the contact spring on the launcher. The forward end of the contact latch is depressed, and the rocket withdrawn sufficiently to expose the ejection pin. If the pin tends to bear against the breech guard, it should be pressed down and held. The safety band is replaced over the ejection pin and secured. The front end of the contact latch is again pressed down so as to clear the rocket head and the rocket removed from the launcher. The insulating tube is pulled back to cover the exposed wire, and the blue contact wire coiled and replaced inside the expansion cone at the rear of the rocket. The shorting clip is then replaced.

If the ejection pin is right out, the rocket must be handled very carefully and THE NOSE KEPT UPWARDS. The rocket must be destroyed as soon as possible. No attempt should be made to replace the pin.

36.0. Preparation for carrying

The barrel locking lever is raised to the unlocked position, the front barrel unscrewed from the rear barrel, and the locking lever then released. The hook on the front barrel is then engaged in the eye on the rear barrel and the barrels pressed together until the barrel latch bolt snaps into position on the bracket fitted to the side of the front barrel.



PART 2 OPERATION

SECTION 2 ACTION OF THE ROCKET

37.0. Preparation (Fig.22)

Before loading, the shorting clip is removed and after the head of the rocket has been inserted in the launcher, the safety band is removed from the fuze (See para. 32).

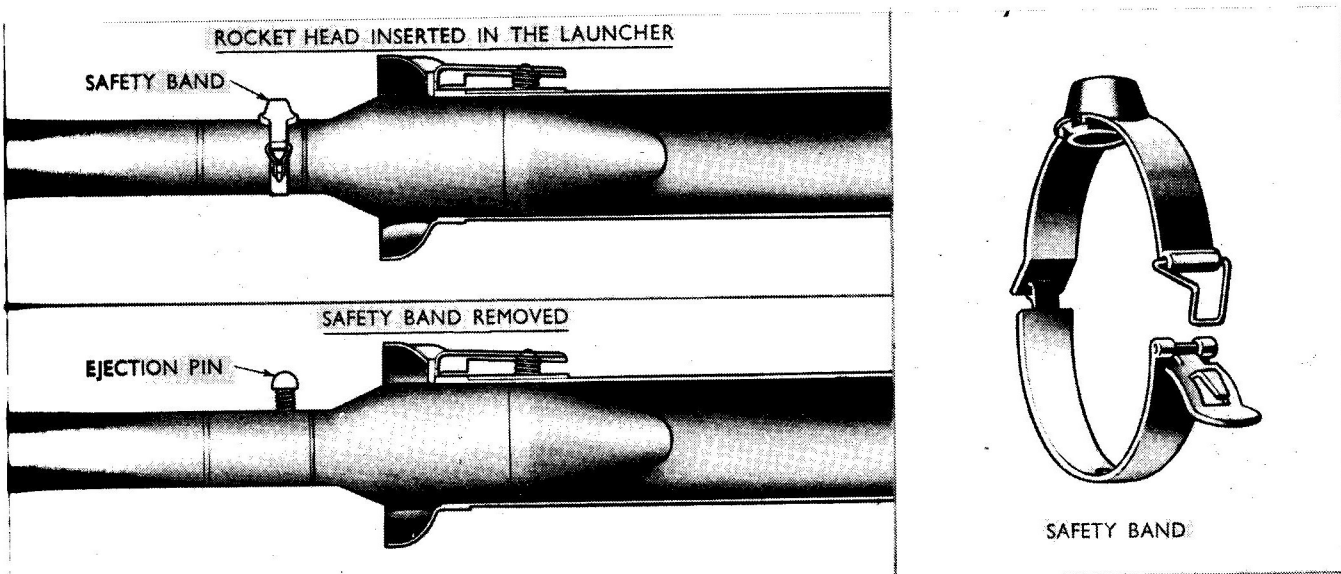

Fig. 22 Preparation for Loading

Removal of the safety band allows the ejection pin to move outwards under the influence of its spring from the safe position to the locked position (Fig.23). In the safe position (i.e. with the safety band on) the setback sleeve was prevented from moving by one of the projections on the ejection pin. In the locked position (i.e. safety band removed) the ejection pin has moved outwards and the second projection on the ejection pin still prevents any movement of the setback sleeve.

When the rocket is completely loaded (Fig.24) the rounded head of the ejection pin coming in contact with the bore of the launcher pushes the pin back to a position midway between safe and locked. In this intermediate position the setback sleeve is not held by the ejection pin and the rocket is prepared for arming.

In the safe, locked, and intermediate positions the detonator is masked from the striker by the slotted stem of the ejection pin.

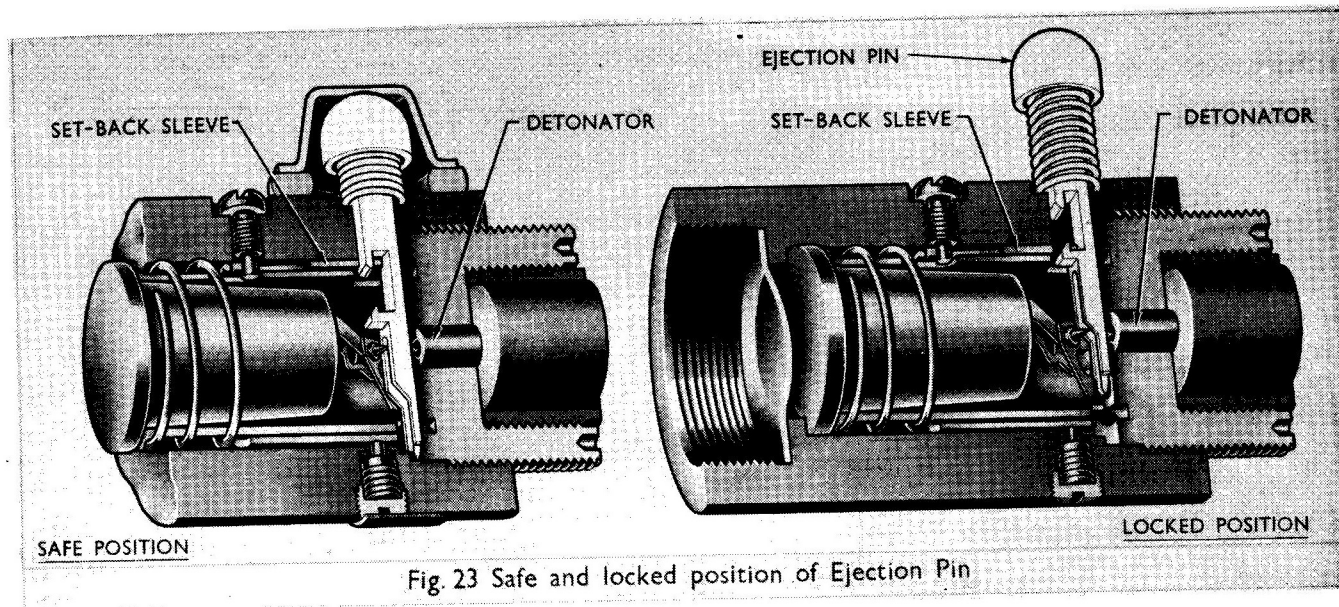
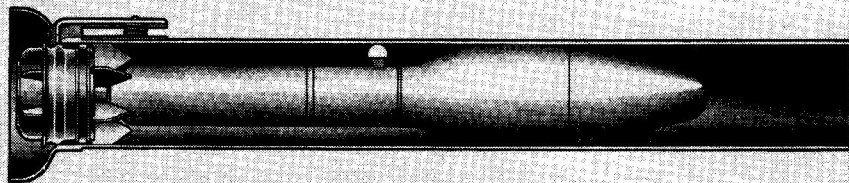

Fig. 23 Safe and locked position of Ejection Pin



ROCKET LOADED IN LAUNCHER

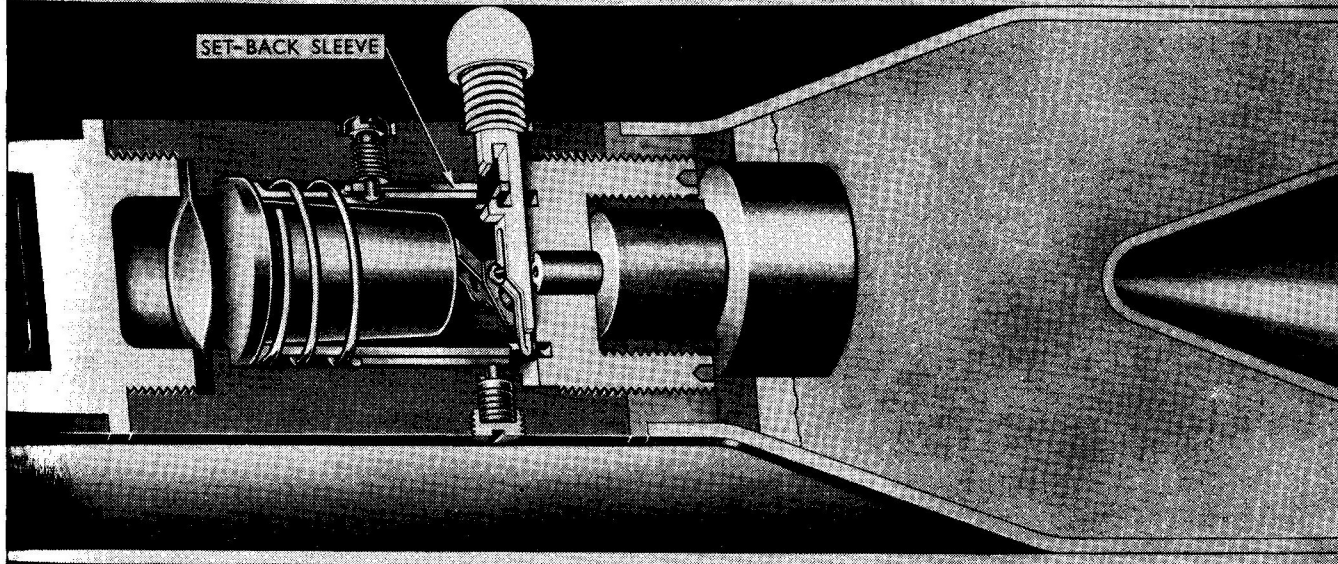

Fig. 24 Rocket completely Loaded



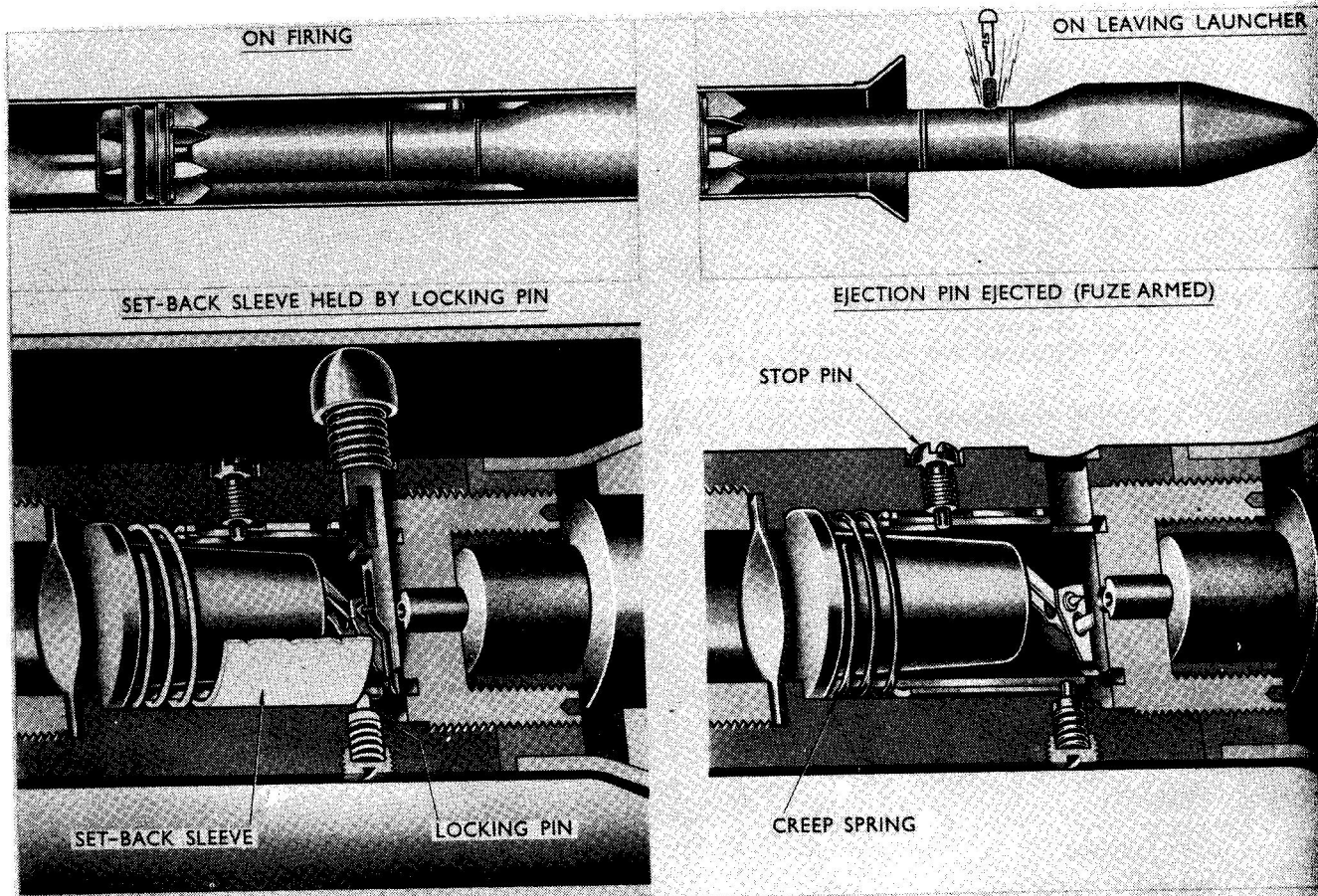

Fig. 25 Action of Fuze on Firing and During Flight

38.0. Action on firing

The pressure set up by igniting the propellant forces the rocket through the bore of the launcher, and the setback sleeve moves to the rear where it is held by the locking pin (Fig.25).

The ejection pin which has been held in position by bearing on the bore of the launcher is ejected under the influence of its spring as soon as the fuze emerges from the launcher and the fuze is now armed.

During flight the setback sleeve and the actuating sleeve are prevented from rotating by the stop pin which passes through a slot provided in both sleeves. The actuating sleeve and plunger are prevented from moving forward by the creep spring. The striker is kept clear of the detonator by a small spring fitted to its frame (Fig.26).

On impact or graze, the inertia plunger and actuating sleeve overcome the force of the creep spring and move forward. The actuating sleeve aided by the weight of the plunger bears on the lugs of the triangular frame on which the striker is mounted. The striker spring is depressed and the striker forced on to the detonator to detonate the filling of the rocket head (Figs.26 and 27).

Due to the shape of the charge, a jet of very high speed and temperature is formed which is capable of penetrating hard armour to a considerable depth and producing lethal damage beyond.

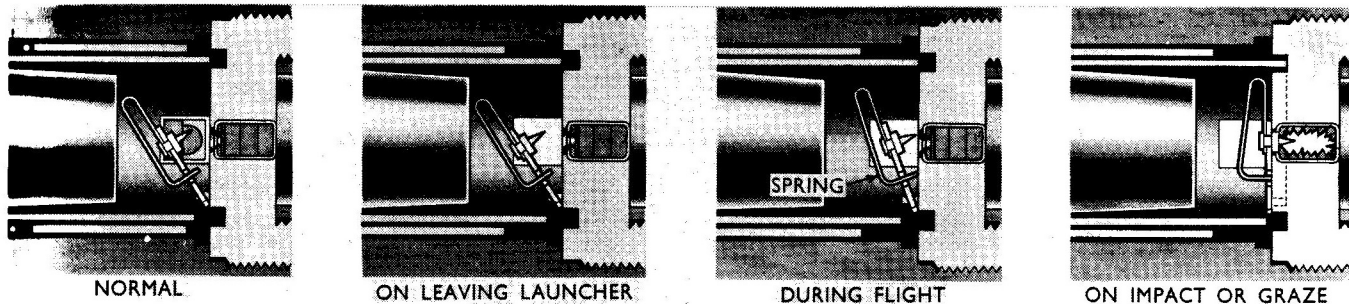
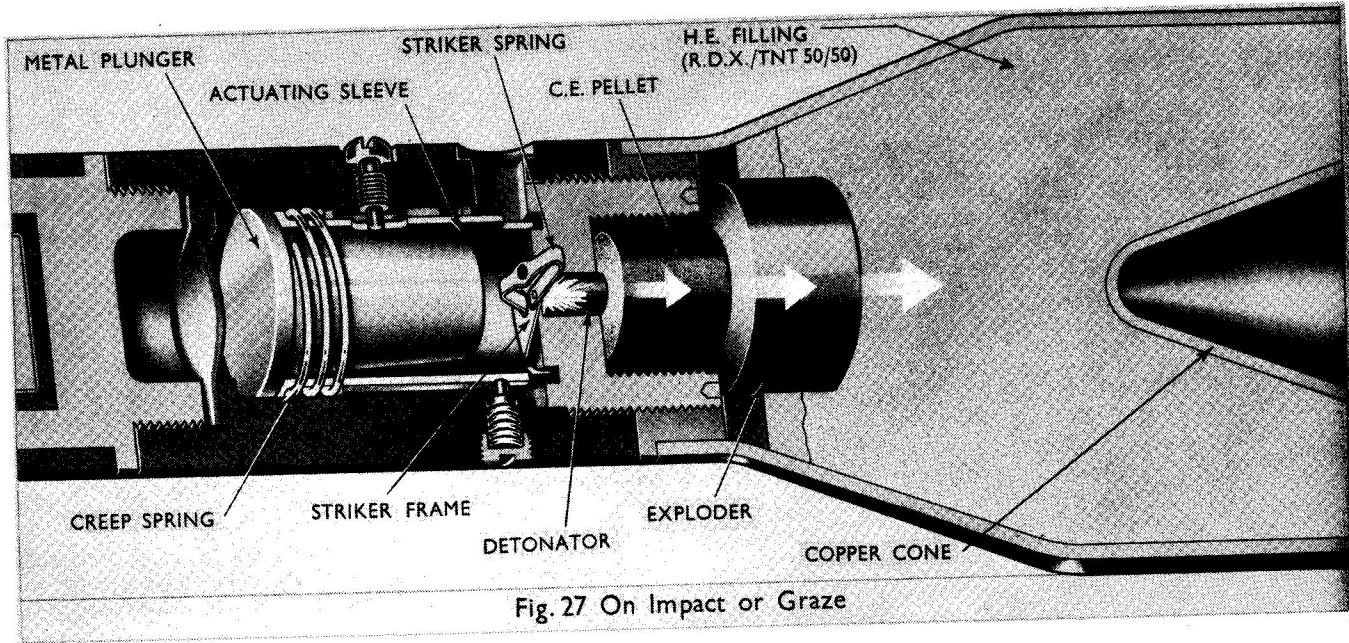

Fig. 26 Action of Striker



PART 3 CARE AND MAINTENANCE

SECTION 1 THE LAUNCHER

39.0. Introduction

The following cleaning materials and preservatives are required for maintenance.

Oil, OX-52 and OM-52 for normal temperatures  
Oil, OX-13 for temperatures below 0°F.  
Cloth, emery, No.00 (Cat. No. HA 12010)

Oil, OX-52 may be used in lieu of OM-52 if necessary.

OX-52 will be used for cleaning all metal parts, or for removing the preservative on exposed surfaces. Paraffin oil will NOT be used.

Under normal conditions, all bearing surfaces of moving parts will be lightly lubricated.

Lubrication will be done carefully and sparingly, and care should be taken to prevent oil touching the rubber eyeguard, and the lens of the sight.

40.0. General

Proper care of the launcher before, during, and after firing should prevent failures of the equipment. In many cases these are caused by a defective firing mechanism or faulty electrical connections.

Rockets with loosely connected contact wires should be placed aside for disposal by the

I.0.0.

Defective firing mechanisms may be due to weak magnets, bad electrical connections or broken parts.

Wiring should be checked for damaged insulation; ensure that the contact spring clamp is properly positioned on the insulating band, and that the band is not damaged.

Care should be taken that the insulating sleeve on the breech end of the aluminium tube insulates the tube from the contact spring clamp; see also that the insulating sleeve is not cracked or damaged.

Inspect the contact latch and ensure that the lugs on which it pivots are secure. The blade at the rear of the contact latch, and the contact surface at the rear of the rocket must be clean and free from oil.

The contact springs must be clean and free from corrosion. They must clamp firmly on the bare end of the rocket blue contact wire.

41.0. The bore  
Before firing, the bore should be clean and dry. After firing, proceed as follows:-

41.1. A cloth with Oil, OX-52 will be run through the bore several times until the bore is clean. The bore should then be dried and a film of Oil, OX-52 applied.

41.2. For three consecutive days after firing, clean and oil as described above. At the fourth cleaning after firing, thoroughly dry and then oil with Oil, OM-52 providing the temperature is above 0 degs. F.; use Oil, OX-13 when temperatures are below 0°F.

42.0. Contact latch

Should be cleaned and oiled regularly. Remove any corrosion or rust with Oil, OX-52, then wipe dry and apply a film of Oil, OM-52. The latch should be dry before firing.

43.0. Firing mechanism

The following operations will be carried out by R.E.M.E. personnel only:-

43.1. Checking serviceability of the firing mechanism with the firing mechanism electrical output tester.

43.2. Replacement of defective firing mechanism.

43.3. Soldering of loose or broken connections.

44.0. Sights

The sight should be handled with care. Rough handling causes inaccuracy and may lead to the equipment becoming unserviceable.

The lens assembly is sealed with an atmosphere of nitrogen to prevent fogging, and stripping of the sight is prohibited. The exposed surface of the lens should be kept clean and dry, and the lens cover kept closed when the sight is not in use. Under no circumstances will polishing liquids or abrasives be used for polishing lenses. Their exterior surfaces should be kept clean with a clean linen cloth used for this purpose only. Particular care must be taken to keep the optical parts free from oil and grease. The rubber eyeguard should be washed occasionally with soap and water.

45.0. Sight Testing

The object of sight testing is to ensure that the line of sight and the bore are parallel. The tests may be carried out with a sight testing board, or on a distance object.

45.1. Using the sight testing board (Fig.28)

- 45.1.1. Insert the plug with the cross wires into the muzzle end of the launcher, and the plug with the peep hole into the rear end.
- 45.1.2. Set the launcher on a firm platform, and position the sight testing board at  $100 \pm \frac{1}{4}$ -inch forward of the front end of the sight mounting bracket.
- 45.1.3. Set the range scale indicator to zero.
- 45.1.4. Adjust the board so that the plumb line coincides with the vertical line of the sight mark on the board.
- 45.1.5. Look through the bore, and align the peep hole and muzzle crosswires of the launcher on the inter-section of the larger cross on the board.
- 45.1.6. Look through the sight, and the horizontal line of the graticule marked 0 must fall within the horizontal arm of the smaller cross on the target board. The vertical line of the graticule must fall within the vertical line of the same cross.

**NOTE.** - The bore plugs and sight testing board will be made locally. The dimensions are shown at Figs. 28 and 29. Bore plugs can be made up from the wooden discs found in the rocket container.

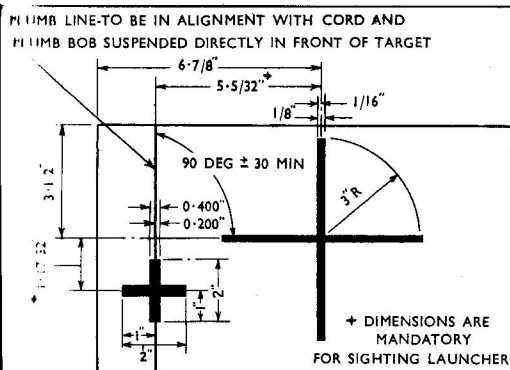
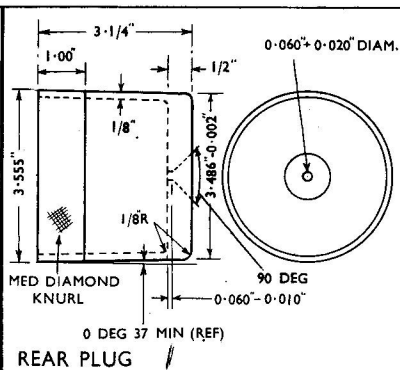
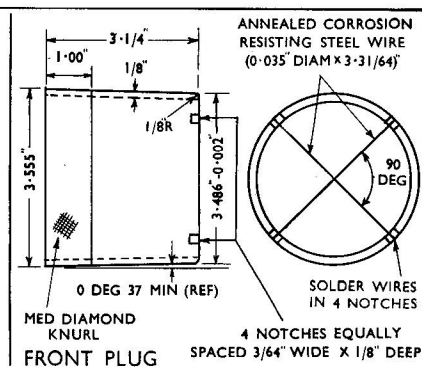

Fig. 28 Sight Testing Board



REAR PLUG



FRONT PLUG

Fig. 29 Bore Plugs

45.2. Distant target method

The launcher can be tested on a distant object as follows:-

- 45.2.1. Select a well defined object at least 1500 yds. distant. At night the moon or a suitable star may be used.
- 45.2.2. Set the launcher on a firm platform.
- 45.2.3. Set the range plate indicator to zero.
- 45.2.4. Sight the bore of the launcher on to the target. This is best done by positioning the eye about three feet behind the launcher so that the target is centred in the bore.
- 45.2.5. Look through the sight, and horizontal line of the graticule marked 0, and the top of the vertical line of the graticule should be on the distant object.

46.0. Adjustments

A screwdriver and an adjustable wrench are required in order to adjust sights. If the range plate is secured by Phillip type Screws, (cruciform slot) a special screwdriver is required.

46.1. Vertical adjustment of the sight is made by loosening the two screws on the range plate and elevating or depressing the sight until the 0 line of the graticule is on the horizontal line of the cross on the board, or on the target. The movement of the sight also moves the range plate reader and the range plate. Check that the pointer is still at zero on the plate and tighten the screws.

46.2. Lateral adjustment of the sight is made by loosening the hinge stud nut and then turning the stud with a screwdriver. The movement of the hinge stud and its detent which is fitting into a seating of the sight frame will bring the line of sight parallel to the vertical axis of the bore (Fig.5). The graduated markings on the yoke (Fig.30) are for reference only. The hinge stud nut is tightened after the adjustment has been made.

47.0. The sight testing procedure should be carried out with the front barrel in each of the three locked positions.

When using the sight testing board the 0 horizontal line, and the vertical line of the graticule, must coincide with the smaller cross on the board when the barrel is in each of the three locked positions.



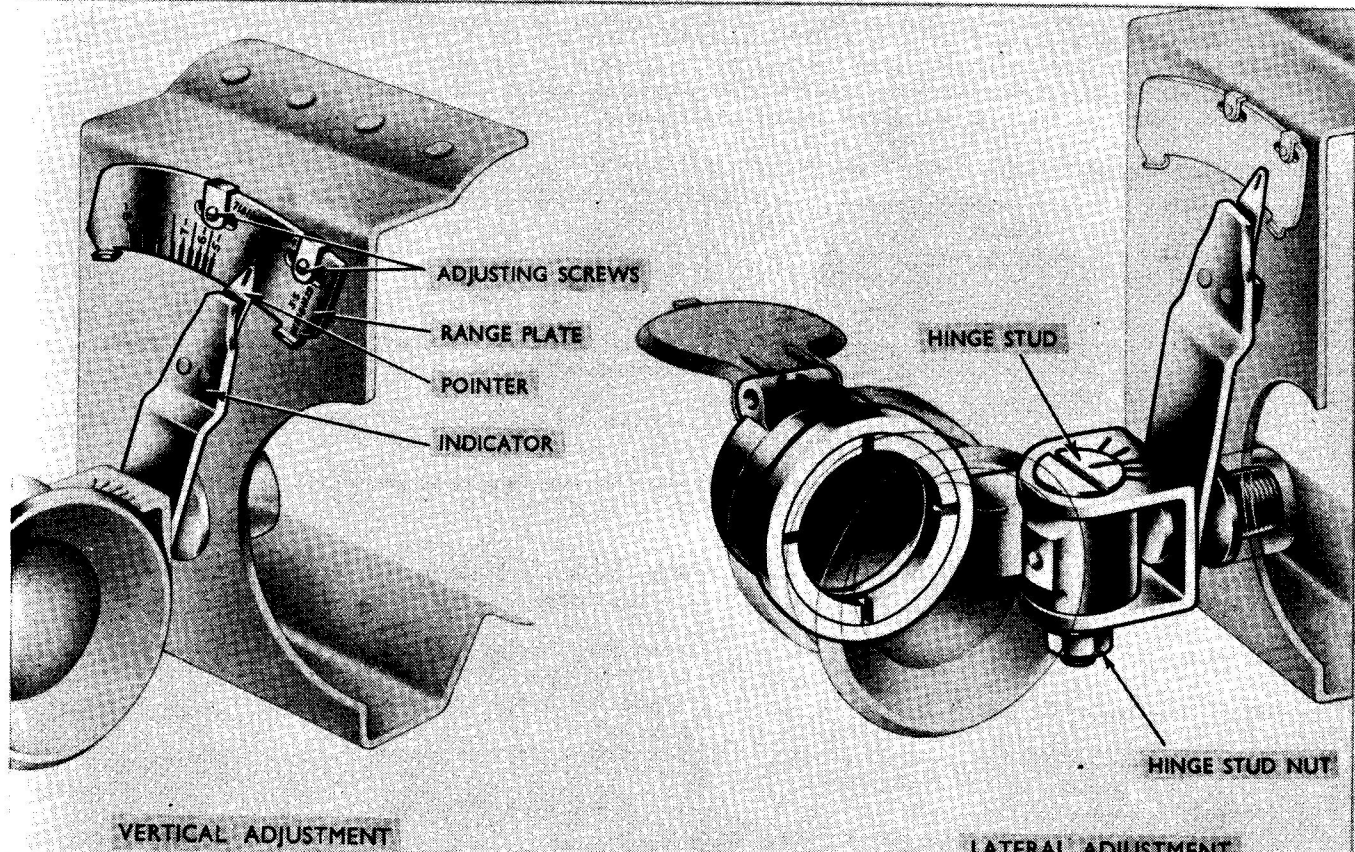

Fig. 30 Sight Adjustments

When using a distant object, the O horizontal line and the top of the vertical graticule line should be on the distant object when the barrel is in each of the three locked positions. After an adjustment has been made to the sight, it will be necessary to repeat the test with the front barrel in each of the three locked positions.

48.0. Task Tables

| Item   | Task  |
|--|---|
| <p><u>DAILY</u></p> <p>Barrel</p> <p>Contact Springs</p>   | <p>Inspect for general condition, loose or broken components, dents or obstructions in bore.</p> <p>Examine to see that they are secure to the clamp and clean.</p>   |
| <p><u>BEFORE FIRING</u></p> <p>Barrel</p> <p>Barrel coupling locking lever and screw</p> <p>Barrel coupling nut</p> <p>Barrel coupling lugs</p> <p>Contact latch</p> <p>Contact springs</p> <p>Sight</p> <p>Wiring and connections</p> | <p>Wipe clean, and check for dents and obstruction in the bore.</p> <p>Test functioning. Check for rust and burrs.</p> <p>Check for burrs and erosion.</p> <p>Check for burrs and erosion.</p> <p>Clean and wipe dry.</p> <p>Check for corrosion, paint, grease or dirt.</p> <p>Check for loose or broken lenses.</p> <p>Check for loose connections and condition of wiring.</p> |

| Item  | Task  |
|---|---|
| <p><u>AFTER FIRING</u></p> <p>All parts</p> <p>Barrel</p> <p>Wiring and connections</p>   | <p>Report any fault experienced or damage resulting from firing.<br/>Correct before next firing.</p> <p>Clean as laid down at para. 41.</p> <p>Check condition.</p>                             |
| <p><u>WEEKLY</u></p> <p>Barrel</p> <p>Barrel coupling locking lever and screw</p> <p>Contactator latch pin</p> <p>Contacting latch</p> <p>Contact springs</p> <p>Firing mechanism</p> <p>Wiring and connections</p> | <p>Clean with Oil, OX-52, wipe dry and oil.</p> <p>Clean and oil.</p> <p>Oil.</p> <p>Clean and oil.</p> <p>Clean.</p> <p>Oil.</p> <p>Check for loose connections, and conditions of wiring.</p> |
| <p><u>MONTHLY</u></p> <p>Contactator latch shunt</p> <p>Firing mechanism</p> <p>Insulating band of contact spring clamp</p>   | <p>Check firmness of fastening.</p> <p>Grips to be removed by authorized personnel.<br/>Clean and oil</p> <p>Inspect for damage.</p>  |

| Item  | Task  |
|---|---|
| <p><u>AS REQUIRED</u></p> <p>Barrel coupling locking lever and screw<br/>Barrel latch</p> | <p>To be stripped as necessary by authorized personnel.</p> |

49.0. Operation under unusual conditions

49.1. Arctic climates

In temperatures below freezing point and particularly in Arctic climates, all operating parts should be kept absolutely free of moisture. Immediately upon being brought indoors the launcher will be cleaned both inside and outside with a clean dry cloth. Remove the trigger grips. Clean, dry and oil the firing mechanism. After it has reached room temperature the launcher should again be cleaned, dried and oiled.

49.2. Tropical climates

In tropical climates where temperature and humidity is high, and during rainy seasons the launcher will be thoroughly inspected and cleaned daily. In humid salty atmosphere, oil the bore and all unpainted metal surfaces every day.

49.3. Hot dry climates

In hot dry climates where sand and dust are liable to get into the bore, the launcher will be wiped clean daily, or more often if necessary. During sand or dust storms the launcher will be kept covered.

PART 3 CARE & MAINTENANCE

SECTION 2 AMMUNITION

50.0. Table of Ammunition

| Nomenclature   | Complete round |                    | Rocket head        |                           | Rocket motor   |                                  | Fuze  |                       | Temperature limits    | Remarks             |
|--|----------------|--------------------|--------------------|---------------------------|--|----------------------------------|---|-----------------------|-----------------------|---------------------|
|  | Length         | Weight             | Filling            | Weight of bursting charge | Propellant   | Weight of propellant             | Nomenclature                                | Type                  |                       |                     |
| Rocket 3.5 inch<br>H.E.A.T U.K. M.28<br>MK.1           | 23.55 in       | 8.9 lb<br>(approx) | RDX/TNT<br>50/50   | 1.82 lb<br>(approx)       | M7 (British)<br>375-121 (tubular)<br>12 sticks each<br>5 in. in length | 5.64 oz<br>(160 grm)<br>(approx) | Fuze Perc.<br>No. L.5<br>U.K. M 404<br>MK.1 | Perc.<br>Non<br>delay | -20° F. to<br>120° F. | U.K.<br>manufacture |
| Rocket Practice<br>3.5 inch U.K. M.29<br>MK.1          | 23.55 in       | 8.9 lb<br>(approx) | None †             | —                         | M7 (British)<br>375-121 (tubular)<br>12 sticks each<br>5 in. in length | 5.64 oz<br>(160 grm)<br>(approx) | Fuze<br>Practice<br>No. L.5<br>MK.2         | —                     | -20° F. to<br>120° F. | U.K.<br>manufacture |
| Rocket H.E.A.T.<br>3.5 inch M.28<br>M.28 A1<br>M.28 A2 | 23.55 in       | 8.9 lb<br>(approx) | Composition<br>"B" | 1.93 lb<br>(approx)       | M7   | 5.76 oz<br>(approx)              | Fuze<br>Rocket<br>B.D.<br>M 404             | Perc.<br>Non<br>delay | -20° F. to<br>120° F. | U.S.<br>manufacture |
| Rocket Practice<br>3.5 inch M.29<br>M.29 A1<br>M.29 A2 | 23.55 in       | 8.9 lb<br>(approx) | None †             | —                         | M7   | 5.76 oz<br>(approx)              | Fuze<br>Rocket<br>Dummy<br>M 405            | —                     | -20° F. to<br>120° F. | U.S.<br>manufacture |

† Head consists of cast iron body with steel ogive and no filler.  
An alternative head consists of steel body and ogive filled  
inert to the required weight.

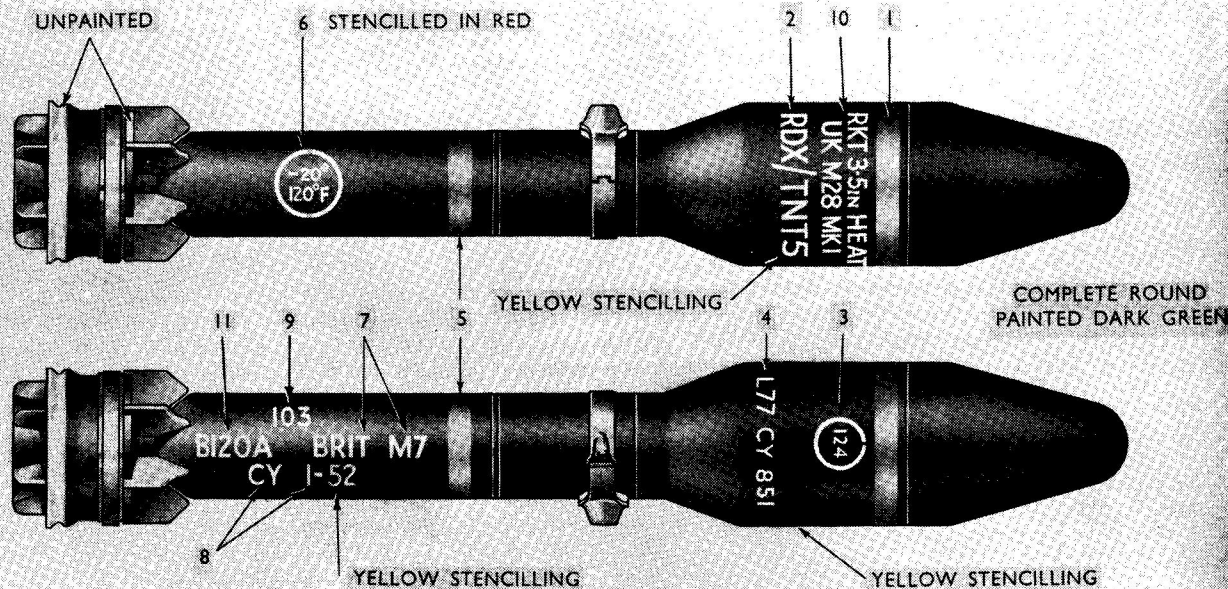

#### HEAD DETAILS

- 1... RED FILLING RING
- 2... CODE (DENOTING FILLING)
- 3... FILLED SERIES NUMBER
- 4... ONE LINE CODE (METHOD OF FILLING, FILLING STATION AND DATE OF FILLING)

#### MOTOR DETAILS

- 5 RED FILLING RING
- 6 FIRING TEMPERATURE LIMITATIONS
- 7 NATURE OF PROPELLANT
- 8 FILLERS RECOGNIZED MARK OR INITIALS AND DATE OF FILLING (MONTH AND YEAR)
- 9 PROPELLANT LOT NUMBER

#### COMPLETE ROUND DETAILS

- 10... NOMENCLATURE AND MARK OF STORE
- 11... BATCH NUMBER

Fig. 31 Painting and Stencilling H.E.A.T. Rocket (U.K. Manufacture)

51.0. Packing

51.1. U.K. manufacture

Each rocket is packed in a hermetically sealed tin plate cylinder with a cardboard lining (Cylinder No.675).

Four cylinders are packed in a wooden box No. M.358.

The exterior of the cylinder is painted dark green with yellow stencilling in the case of the H.E.A.T. rocket, and light blue with stencilling in white for the practice rocket.

The nomenclature of the complete package is Package, Ammunition, No.62.

One end of the rocket cylinder is closed by a cap secured by a tear-off metal strip. Removal of the tear-off strip, and the cap exposes the tail of the rocket.

The weight of the box with four rockets in their cylinders is 67 lbs. A single rocket in its cylinder weighs 12 lbs.

51.2. U.S.A. manufacture

Each rocket is packed in a hermetically sealed metal cylinder, and three cylinders packed in a wooden box.

The exterior of the cylinder is painted dark green with yellow stencilling for H.E.A.T. rockets, and blue with stencilling in white for practice rockets.

The weight of the box with three rockets in their cylinders is 53 lbs.

52.0. Painting and stencilling

52.1. H.E.A.T. Rocket (U.K. manufacture)

All components of the rocket i.e. rocket head, fuze and motor, are painted dark green.

The fuze safety band is unpainted.

All stencilling will be in yellow except the temperature limitations marked on the motor which are in red.

The contact ring is unpainted and also a section at the front of the aluminium support ring over which is fitted the shorting slip.

Details are shown at Fig.31.

52.2. Practice Rocket (U.K. manufacture)

The rocket head and fuze are painted blue with stencilling in white.

The fuze safety band is unpainted.

The rocket motor is painted dark green with stencilling in yellow except the temperature limitations marked on the motor which are in red.



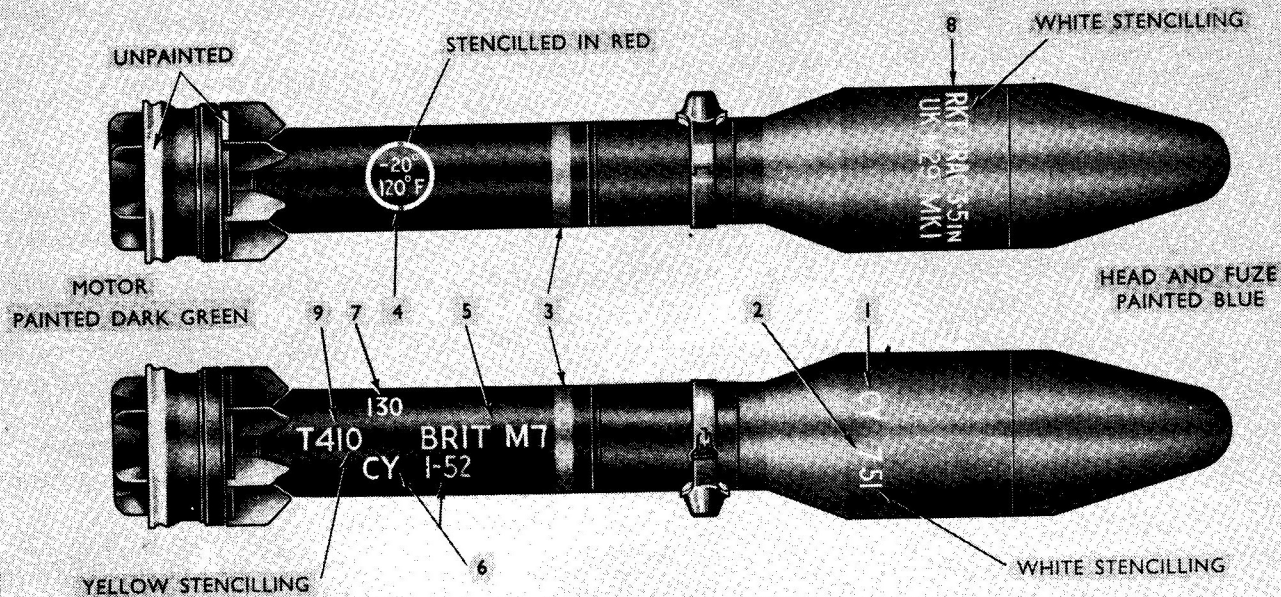

#### HEAD DETAILS (IF APPLICABLE)

- 1... FILLERS RECOGNIZED MARK OR INITIALS
- 2... DATE OF FILLING (MONTH AND YEAR)

#### MOTOR DETAILS

- 3 RED FILLING RING
- 4 FIRING TEMPERATURE LIMITATIONS
- 5 NATURE OF PROPELLANT
- 6 FILLERS RECOGNIZED MARK OR INITIALS AND DATE OF FILLING (MONTH AND YEAR)
- 7 PROPELLANT LOT NUMBER

#### COMPLETE ROUND DETAILS

- 8... NOMENCLATURE AND MARK OF STORE
- 9... BATCH NUMBER

Fig. 32 Painting and Stencilling Practice Rocket (U.K. Manufacture)

The contact ring is unpainted and also a section at the front of the aluminium support ring over which is fitted the shorting clip.

Details are shown at Fig.32.

52.3. H.E.A.T. Rocket (U.S.A. manufacture)

All components of the rocket are painted olive drab.

The fuze safety band is unpainted.

All stencilling will be in yellow.

The temperature limitations are marked on the rocket head.

The markings will include the type, size and model; the ammunition lot number which consists of the fillers' initial or symbol and lot number and the month and year of filling.

The contact ring is not painted.

52.4. Practice Rocket (U.S.A. manufacture)

The head and fuze are painted blue with markings in white.

The fuze safety band is unpainted.

The motor is painted olive drab.

Temperature limitations are marked on the rocket head.

The markings will include type, size and model, fillers' initial or symbol and lot number and the month and year of filling.

The contact ring is not painted.

53.0. Care and Preservation

Care and preservation of ammunition is of the utmost importance. Great care is taken both during manufacture and packing to ensure that it reaches the unit in good condition, and its serviceability thereafter will depend upon the care and attention given by the unit. Ammunition must be treated reasonably and intelligently at all times.

Service ammunition must not be used for drill purposes.

When stored in the open, packages should be raised at least six inches from the ground and covered with tarpaulin, leaving sufficient space for air to circulate.

53.1. As explosives are adversely effected by high temperature and moisture, consideration should be given to the following points:-

53.1.1. Do not break the hermetically sealed metal containers until ammunition is to be used.

- 53.1.2. Protect ammunition from sources of high temperature including the direct rays of the sun. Rockets should not be stored where the temperature may exceed 120 degrees F.
- 53.1.3. Rockets must not be disassembled.
- 53.1.4. Protection should be provided as far as possible from mud, sand, dirt and water. Rounds which are dirty or wet must be wiped with a clean dry cloth.
- 53.1.5. Rockets with damaged fins will not be fired as this will result in unstable flight and erratic ranges. When loading into the launcher, care will be taken to prevent damage to the fin blades.
- 53.1.6. In handling and storage, complete rounds must be kept pointed in that direction which would result in the least damage should the propellant be accidentally ignited.
- 53.1.7. Rounds prepared for firing but not used will be returned to their original packages and appropriately marked. They will be used first in subsequent firings so that stocks of open packages are kept to a minimum.
- 53.1.8. Unexploded rockets are extremely dangerous and should not be moved or touched. They should be destroyed as they occur in accordance with the procedure laid down in the Drill Book and I.T. Vol.3, Pamphlet No.31, Range Work - General (All Arms) 1948, Appendix "C".
- 53.1.9. Misfired rounds will be set aside for examination and sentence by the I.O.O.